

FIRE AND SECURITY

AUTRO SAFE

Self Verify®

Interactive Fire Alarm System
Release 3



Installation Handbook

Fire Alarm Control Panel, BS-310/320
Controller, BC-320

Protecting life, environment and property...



116-P-ASAFE-FA/DE, Rev. G, 2007-06-19

COPYRIGHT ©

This publication, or parts thereof, may not be reproduced in any form, by any method, for any purpose.

Autronica Fire and Security AS and its subsidiaries assume no responsibility for any errors that may appear in the publication, or for damages arising from the information in it. No information in this publication should be regarded as a warranty made by Autronica Fire and Security. The information in this publication may be updated without notice.

Product names mentioned in this publication may be trademarks. They are used only for identification.



Table of Contents

1. Introduction	4
1.1 About the Handbook	4
1.2 The Reader	4
1.3 Reference Documentation	5
1.4 Environmental Requirements	6
1.5 Equipment List	6
1.6 Assembly Drawing	7
2. Mounting	9
2.1 Introduction	9
2.2 Location	9
2.3 Mounting Height / Space Requirement	9
2.4 Cabinet Dimensions	10
2.5 Surface Mounting	11
2.5.1 Removing the Front Panel	11
2.5.2 Mounting the Cabinet	13
2.5.3 Cable Inlets / Outlets	14
2.5.4 Cable Connections	14
2.5.5 Mounting the Batteries	15
2.5.6 Reassembling the Front Panel	16
2.6 Flush Mounting in a Wall	17
2.6.1 Removing the Front Panel	17
2.6.2 Removing the Mounting Plate	17
2.6.3 Flush Mounting Before Construction of the Wall	18
2.6.4 Cut Out Dimensions	19
2.6.5 Mounting the Cabinet	20
2.6.6 Reassembling the Mounting Plate	20
2.6.7 Cable Inlets / Outlets	21
2.6.8 Cable Connections	21
2.6.9 Mounting the Batteries	21
2.6.10 Reassembling the Front Panel	21
2.6.11 Mounting Several Panels in a 19" Rack	21
3. Internal Cable Connections	22
3.1 Introduction	22
3.2 Before Connecting Cables	22
3.3 Location of Fuses	23
3.3.1 Fuses on Power Supply, BSS-103A/02	23
3.3.2 Fuses on Connection Module, BSF-310B	24
3.4 Shielding and Earthing	25
3.4.1 Introduction	25
3.4.2 Definitions	25
3.5 Power Supply and Battery Connections	26
3.5.1 Connecting 230 VAC to Power Supply BSS-103A/02	26
3.5.2 Connecting the Batteries to Connection Module and Power Supply	27

3.6	Connecting the Network Cables (AUTROLON).....	28
3.6.1	External AUTROLON Cables	28
3.6.2	Internal AUTROLON Cable.....	28
3.7	Internal Cable Connections - Overview	29
3.8	Connections for Temperature Compensated Battery Charging Voltage.....	31
3.8.1	Introduction	31
3.8.2	Connecting the Cable to External Temperature Sensor.....	32
4.	Installing I/O Modules.....	34
4.1	Introduction.....	34
4.2	Front View of I/O Module	34
4.3	Mounting / Removing I/O Modules.....	35
4.3.1	General	35
4.3.2	Mounting	35
4.3.3	Removing.....	36
4.3.4	Before Connecting Cables.....	36
4.4	Data Sheets - I/O Modules.....	36
4.5	Power Module, BSS-310.....	37
4.6	Communication Module, BSL-310	38
4.7	Loop Driver Module, BSD-310 / BSD-311	39
4.8	Output Module, Monitored, BSB-310	40
4.9	Output Module, BSJ-310.....	41
4.10	Input Module, Monitored, BSE-310	42
4.11	Input Module, BSE-320	43
5.	Connections to Detectors	44
5.1	Connecting Detectors.....	44
5.2	LED Connection on Detector	44
5.3	Connection of Branch-off	45
5.4	Detector Head / Base Alignment.....	46
5.5	Detector Label	46
5.6	Detector Dust Covers.....	47
6.	Connections to Other Loop Units	48
6.1	Introduction.....	48
6.2	Manual Call Points	48
6.3	AutoSense 100 Aspirating Detector.....	49
6.4	AutoSense 75 Aspirating Detector.....	50
6.5	Flame Detection with AutoFlame	51
6.5.1	AutoFlame X33/1	51
6.5.2	AutoFlame CCTV.....	52
6.6	Line Detection with AutoBeam 100.....	53
6.7	Line Detection with AutoBeam 25.....	54
6.8	Programmable Electronic Sounders on the Detection Loop.....	55
6.9	Addressable Socket Sounder.....	56
6.10	Ex ia-Approved Detectors	57
6.11	Disable Input with Pushbuttons.....	58
6.12	Disable Input with Timer Input.....	59
6.13	Day/Night Control Unit with Pushbuttons.....	60
6.14	Day/Night Control Unit with Timer Input.....	61
6.15	Connection of Door Control Unit	62

6.16	Connection of Standard Control Unit	63
6.17	Connection of Sprinkler Control Unit.....	64
6.18	Connection of Remote Alarm Control Unit.....	65
6.19	Connection of Interface Unit for Conventional Loops	66
7.	Larger Distributed Systems	67
7.1	AUTROLON Rings with Cable Lengths >1km	67
7.2	Limitations when using AUTROLON Boosters	67
7.3	Overview - Cable Connections.....	68
7.4	Connections to the AUTROLON Booster BSL-325	68
8.	Interfacing AutoMaster 5000	69
8.1	General.....	69
8.2	Connections - Overview	70
8.3	Application with several AUTROLON rings.....	71
8.3.1	General	71
8.3.2	Application with Twisted Pair Cabling.....	72
8.3.3	Application with Fibre Optic Cabling	73
9.	Guidelines for the Installation and Addressing of Loop Units	74
9.1	Introduction.....	74
9.2	Parameters Used During Configuration	74
9.3	Which Parameters are Known?	76
9.4	Guidelines - <i>Known</i> Cable Layout.....	76
9.5	Guidelines - <i>Unknown</i> Cable Layout.....	77
10.	Service and Maintenance	78
10.1	Introduction.....	78
10.2	Monthly Maintenance	78
10.3	Annual Service and Maintenance	79
11.	Reader's Comments	81

1. Introduction

1.1 About the Handbook

This handbook is intended to provide all necessary information for the installation of the AutoSafe Fire Alarm Control Panel (BS-310/320) and the Controller BC-320. It also gives detailed information on connections to the network (AUTROLON), loop unit connections (detectors and other loop units), as well as guidelines for the installation and addressing of loop units.

The Fire Alarm Control Panel and the Controller are identical as far as installation procedures are concerned. Note that all illustrations throughout this handbook shows the Fire Alarm Control Panel with buttons, indicators and display. The Controller has a front blackplate, and the Display Board BSR-310, Operator Board BZ-310 and Processor Board EAC-300 are not integrated parts of the system unit.



POWER OFF!

Note that this handbook deals with the mechanical and electrical installation only. All tasks described in the handbook are to be performed without applying power to the system.

Power must not be applied before commissioning, refer to Commissioning Handbook.

The chapter «Service and Maintenance» outlines the recommended monthly and annual service and maintenance procedures.

1.2 The Reader

The handbook is intended to be used by Autronica Fire and Security trained service and technical personnel who are responsible for the installation of the AutoSafe Interactive Fire Alarm System.

1.3 Reference Documentation

In addition to this handbook, Autronica Fire and Security offers the following documentation:

Handbook	Item Number
System Specification	P-ASAFE/XE
Installation Handbook, Fire Alarm Control Panel (BS-310/320) / Controller (BC-320)	P-ASAFE-FA/DE
Installation Handbook, Operator Panel (BS-330)	P-ASAFE-OP/DE
Installation Handbook, Repeater Panel (BU-320) / Information Panel (BV-320)	P-ASAFE-RI/DE
Installation Handbook, Battery Cabinet (SY-310)	P-ASAFE-BC/DE
Commissioning Handbook	P-ASAFE/EE
Operator's Handbook, Fire Alarm Control Panel (BS-310/320) / Operator Panel (BS-330)	P-ASAFE-FO/FE
Operator's Handbook, Repeater Panel (BU-320)	P-ASAFE-FB/FE
Operator's Handbook, Information Panel (BV-320)	P-ASAFE-IN/FE
Shortform User Guide	P-ASAFE-SH/LE
Shortform Configuration Guide (for the AutoSafe Demo Board)	P-ASAFE-SH/VE
Wall Chart	P-ASAFE-WE/LX
Wall Chart	P-ASAFE-CH/LX
Menu Structure	P-ASAFE/MX
User Guide, Loop Diagnostic Tool, AS-2000	P-ASAFE-AS/FE
User Guide, Loop Simulator Tool	P-ASAFE-LS/FE
User Guide, Loop Calculator Tool	P-ASAFE-LC/FE
User Guide, Merge Tool	P-ASAFE-MT/FE
User Guide, Power Calculator Sheet	P-ASAFE-PC/FE

1.4 Environmental Requirements

The equipment complies to environmental conditions of IEC-721-3-3 class 3k5.

Ambient temperature:-5 to +40 C
Degree of protection:IEC-529/IP30

1.5 Equipment List

The AutoSafe *Fire Alarm Control Panel* consists of the following:

BS-310/01: Operator front panel *, complete with:

BSR-310:Display Board with LCD
BSZ-310Operator Board
EAC-300Processor Board

Option:

BUP-310Printer
EAU-310LON Interface (BS-320 type)
EAU-321Serial Port Communication Board
EAU-330Ethernet Communication Board

BC-310/01:Controller rear cabinet
UEA-323:Cabinet (H=321 mm, W=315 mm, D=139 mm)
BSL-310:Communication Module
BSF-310:Connection Module
BSS-310:Power Module
BSS-103A/02: Power Supply

Options:

Batteries2 x 12V / 12Ah (maximum)

Modules:

BSD-310Loop Driver Module (127 addresses)
BSD-311High-power Loop Driver Module
BSB-310Output Module (4 relays, monitored)
BSJ-310Output Module (8 open collector outputs)
BSE-310Input Module (4 inputs, monitored)
BSE-320Input Module (8 inputs, galvanic isolated)

* The Controller serves as a connection unit for Loop Driver Modules, I/O modules and power supply only. The cabinet is thus delivered with a black panel in front instead of the Operator Front Panel.

1.6 Assembly Drawing

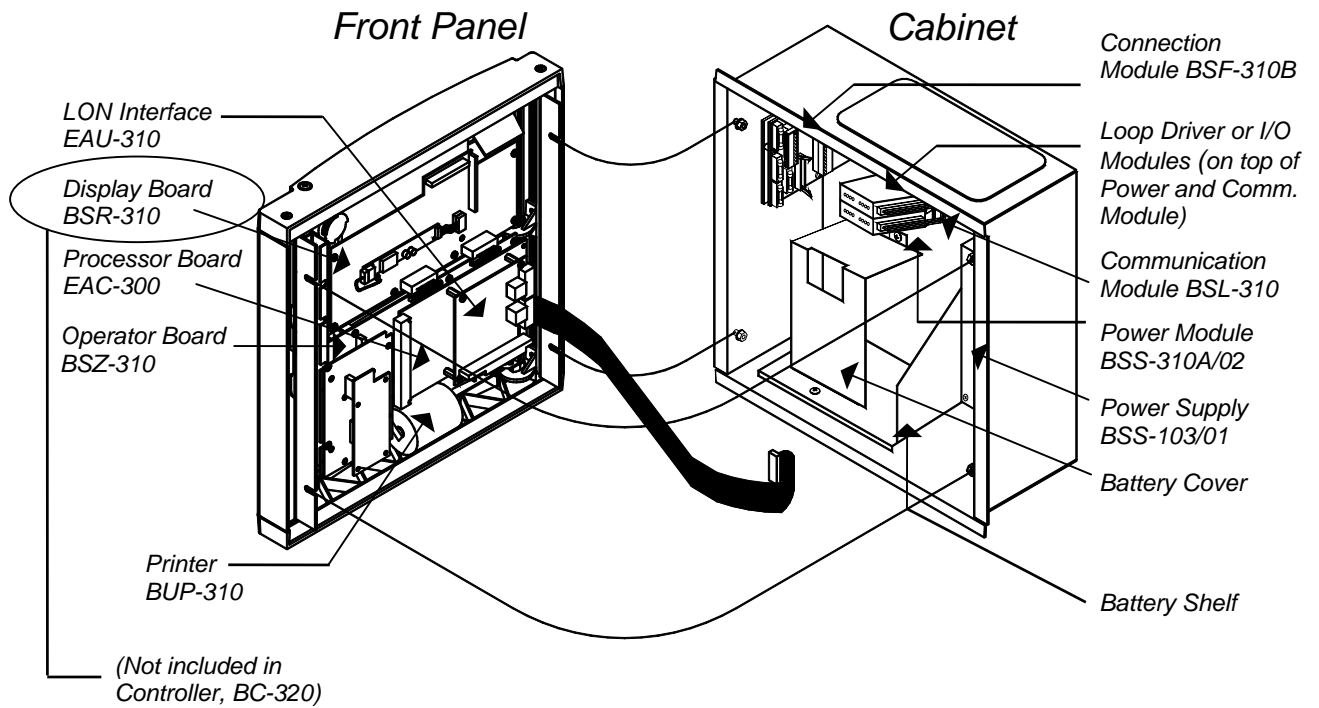

2. Mounting

2.1 Introduction

This chapter deals with the following mounting alternatives:

- Surface mounting
- Flush mounting in a wall

For *surface mounting* and *flush mounting in a wall*, a stand-alone cabinet is used.

2.2 Location

The Fire Alarm aControl Panel must be located in, or near by, the entrance. Both the Fire Alarm Control Panel and the Controller must be placed according to local regulations and in consultation with the fire brigade.

2.3 Mounting Height / Space Requirement

To ensure optimal readability of the Fire Alarm Control Panel's display, the recommended mounting height of this cabinet top is approximately 175 cm above the floor.

For surface mounting and flush mounting in a wall, there must be a free space of minimum 50 mm from the cabinet top to the ceiling in order to fasten the top screw on the front panel door after the installation. A crosshead screwdriver can be used for this purpose.

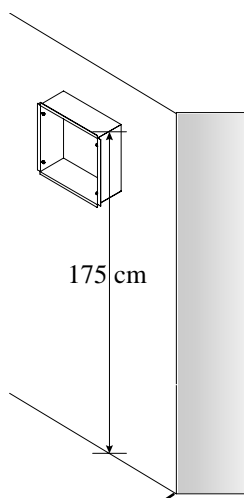

2.4 Cabinet Dimensions

The cabinet (Fire Alarm Control Panel / Controller) has the following dimensions:

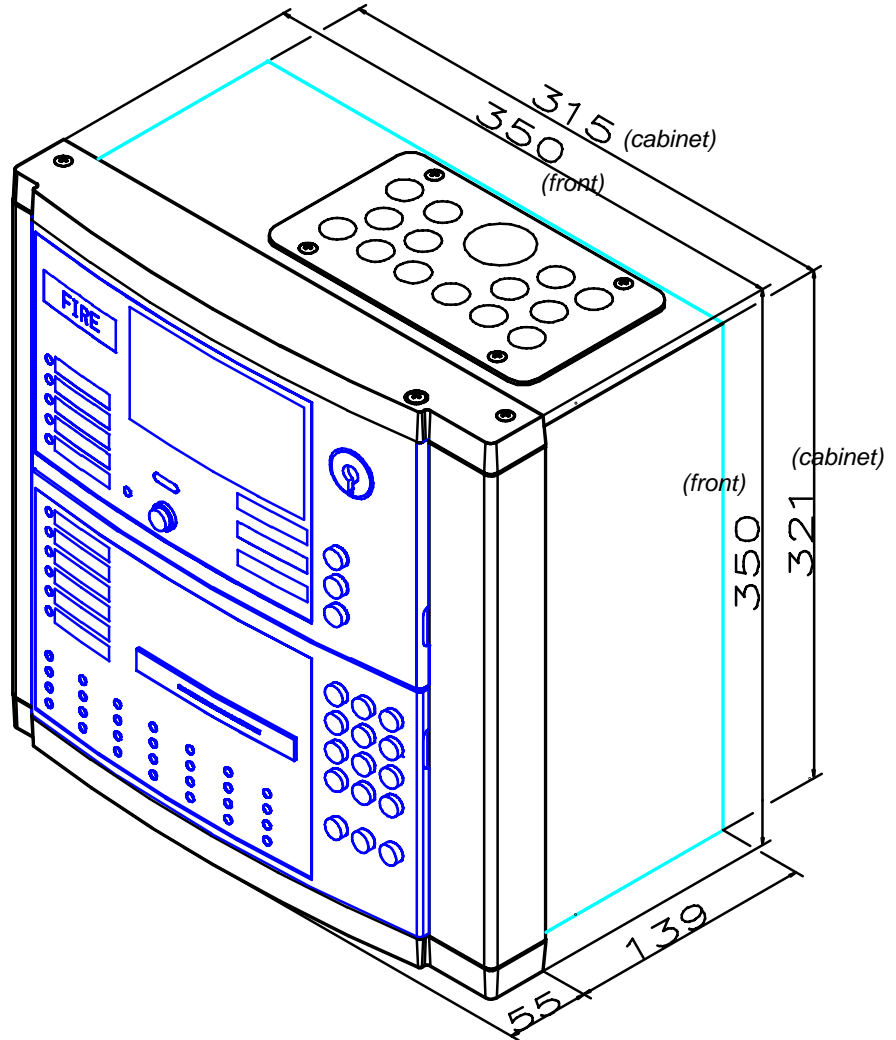

(Ref. BS-1109)

2.5 Surface Mounting

2.5.1 Removing the Front Panel

All the internal units within the rear cabinet are fastened to a mounting plate. The cabinet is delivered with the front panel fastened to the cabinet.

- Unscrew the 2 screws on the top and the bottom on the right hand side of the front panel.

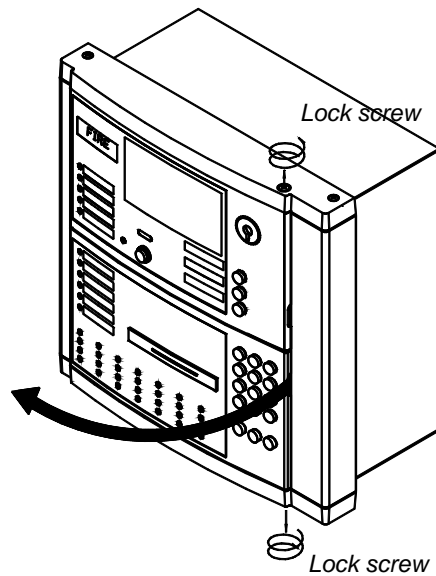

- Open the front panel.

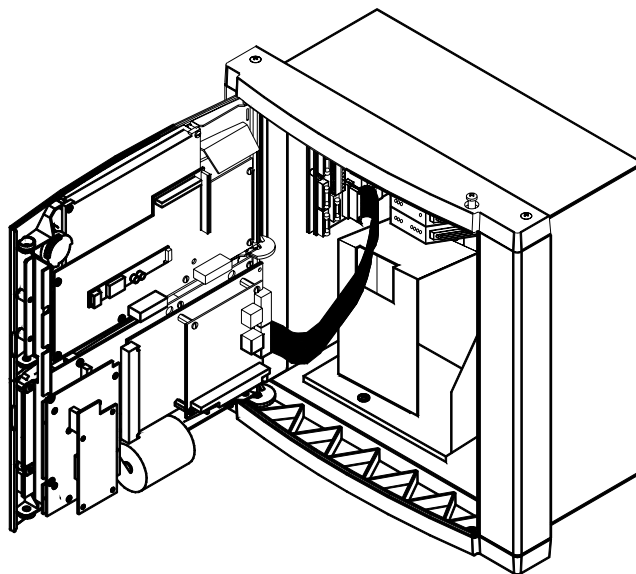

- Disconnect the ribbon cable(s) between the front panel and the cabinet by removing the connector on the BSF-310B board.

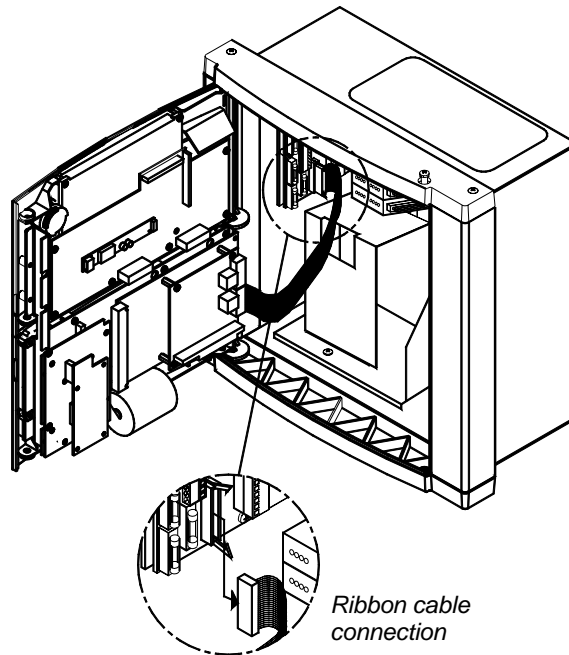

- Unscrew the 4 wing nuts on the right and left hand side of the cabinet, then close the front panel, and remove the front panel from the cabinet .

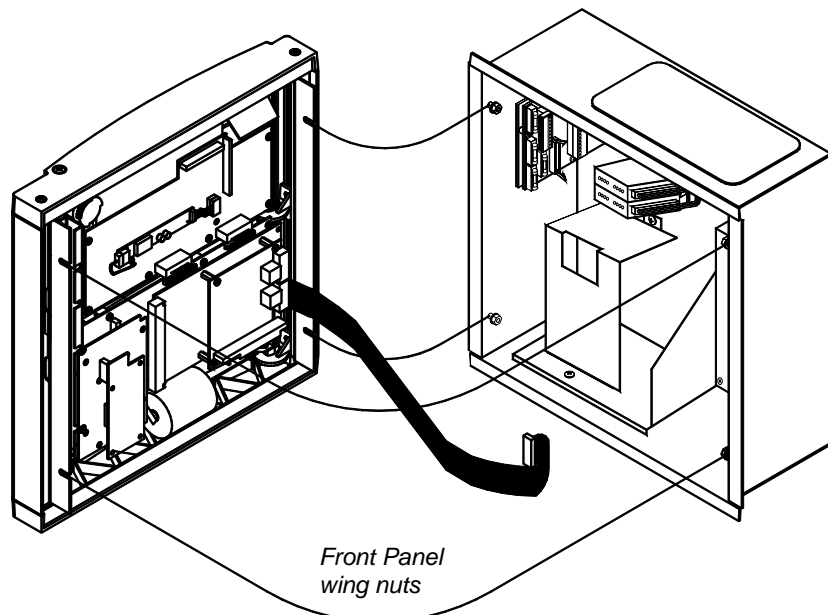

2.5.2 Mounting the Cabinet

The cabinet has 5 mounting holes located at the rear. The upper holes are of key-hole-type.

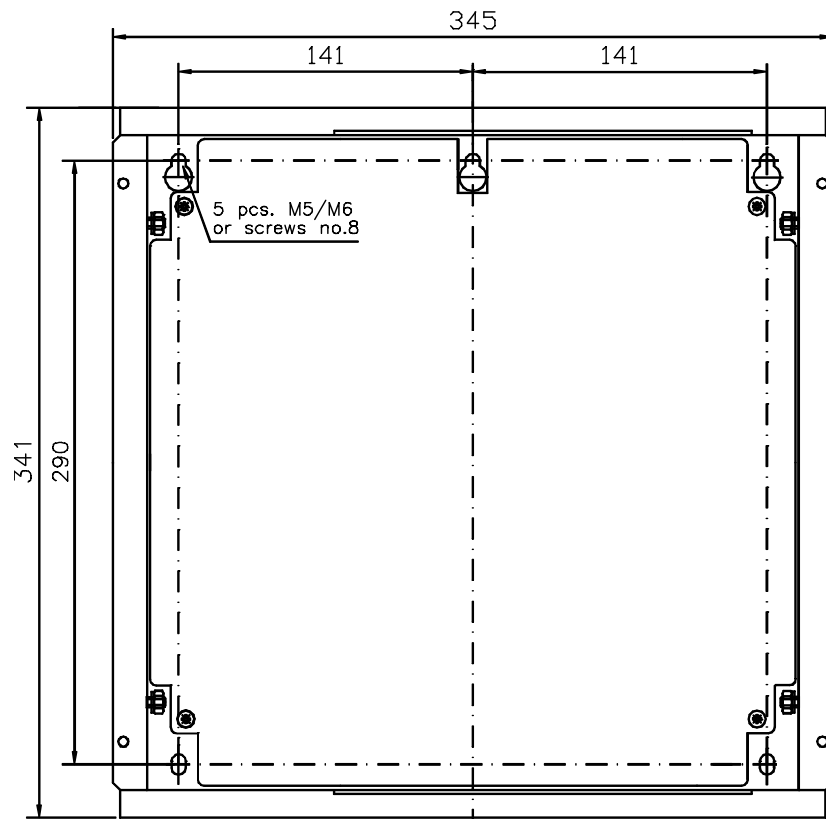

Consult the illustration above, and do the following:

- Mark and drill all the holes according to the illustration.
- Partly fasten the upper screws.
- Hang the cabinet onto the upper screws.
- Partly fasten the bottom screws.
- Tighten all screws.

2.5.3 Cable Inlets / Outlets

Note that two gland plates are fitted to the cabinet, one with predrilled holes and one blank. When feeding the cables, use whichever is appropriate. Entry should always be from top as bottom entry is restricted, particularly if batteries are fitted.

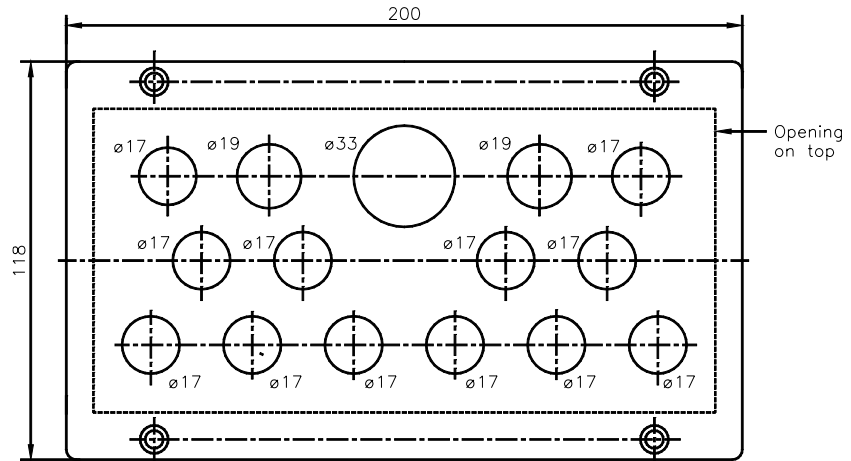

The illustration above shows the positioning and dimensions of the cable inlets.

- Feed all the cables into the cabinet from the top through the suitable cable inlets.
- Make sure that the cables are fastened properly.

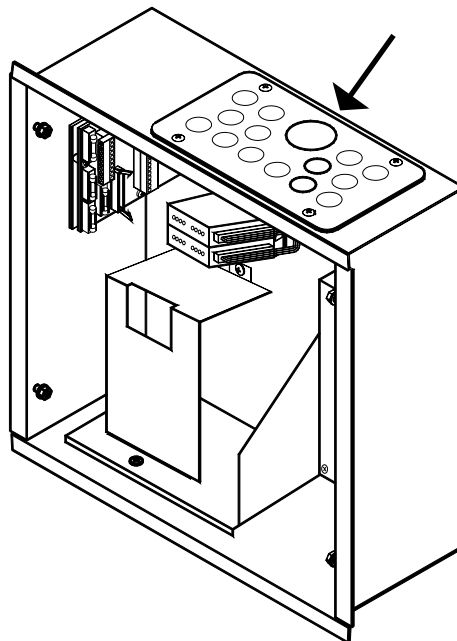

2.5.4 Cable Connections

For detailed information on cable connections, refer to chapter 3 in this handbook.

2.5.5 Mounting the Batteries

- Unscrew the screw as shown on the illustration below.
- Lift the lower part of the cover off the bottom slot and remove the battery cover.

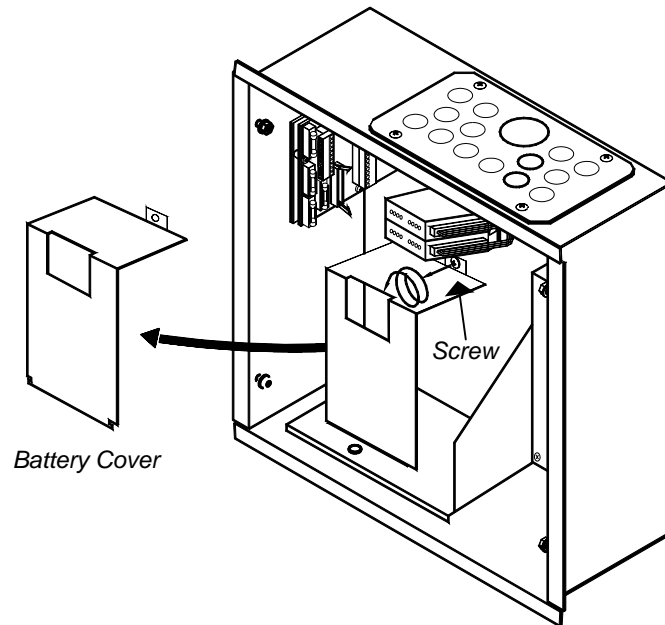

- Place the batteries in their position as shown, then reassemble the battery cover.

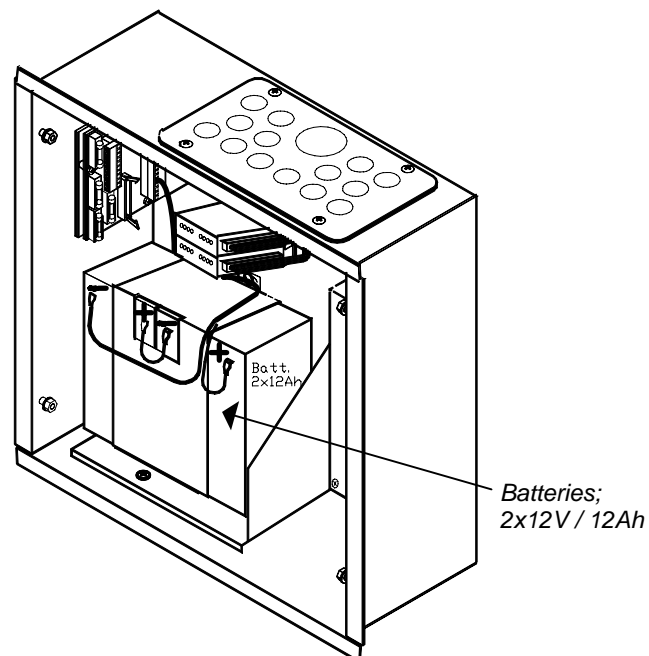

2.5.6 Reassembling the Front Panel

- When all the necessary cable connections are done, reassemble the front panel.
- Open the front panel.
- Tighten the 4 wing nuts on the right and left side inside the cabinet.
- Interconnect the ribbon cable(s) between the front panel and the cabinet.
- Close the front panel, and tighten the two lock screws on the top and the bottom on the right hand side.

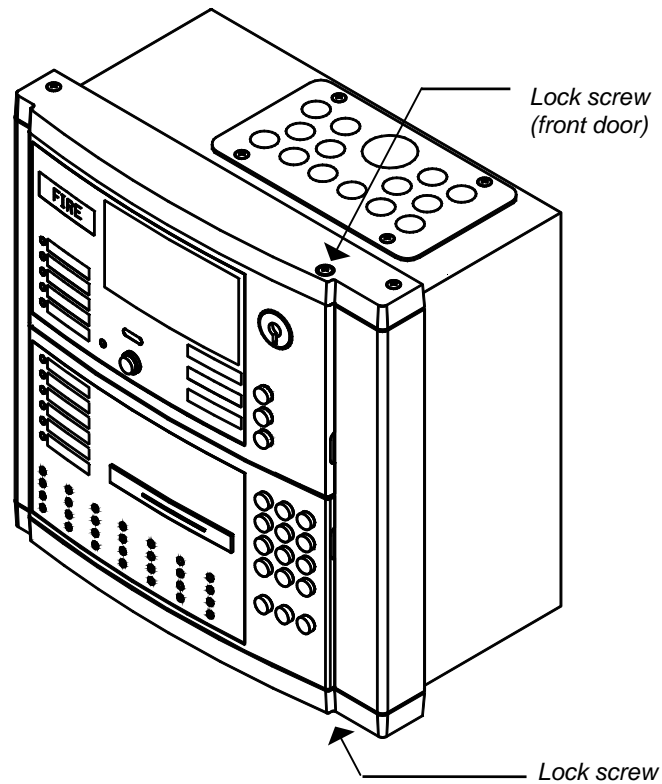
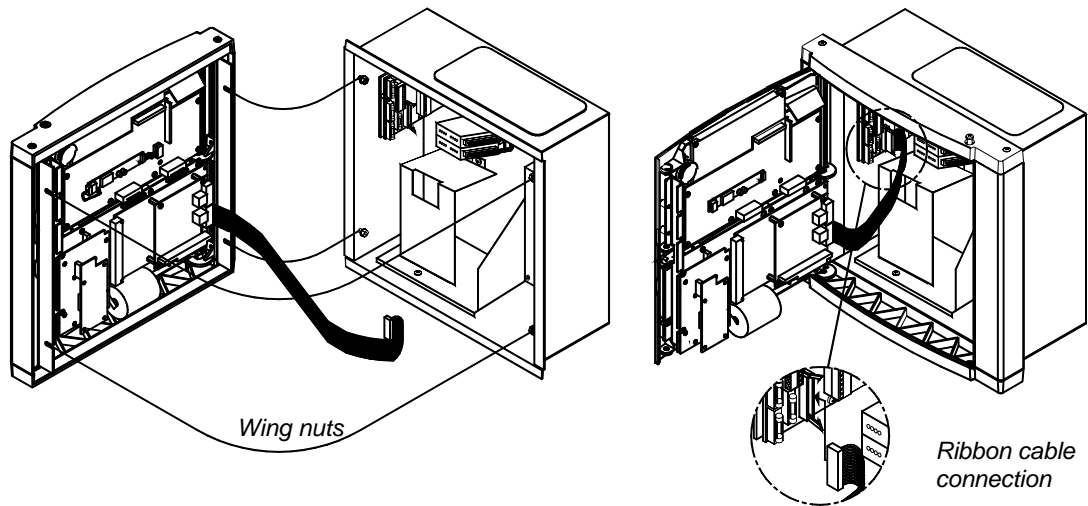

2.6 Flush Mounting in a Wall

2.6.1 Removing the Front Panel

All the inside units in the cabinet are fastened to a mounting plate. The cabinet is delivered with the front panels fastened to the cabinet.

- Follow the procedure described in *chapter 2.5.1*;
 - unscrew the 2 screws on the top and the bottom on the right hand side of the front panel and open it.
 - disconnect the ribbon cables between the front panel and the cabinet by removing the connector on the BSF-310B board.
 - unscrew the 4 wing nuts on the right and left side inside the cabinet and remove the front panel from the cabinet.

2.6.2 Removing the Mounting Plate

To avoid damaging the electronics, the mounting plate inside the cabinet should be removed.

- Unscrew the 5 screws on the mounting plate inside the cabinet and carefully lift it out of the cabinet.

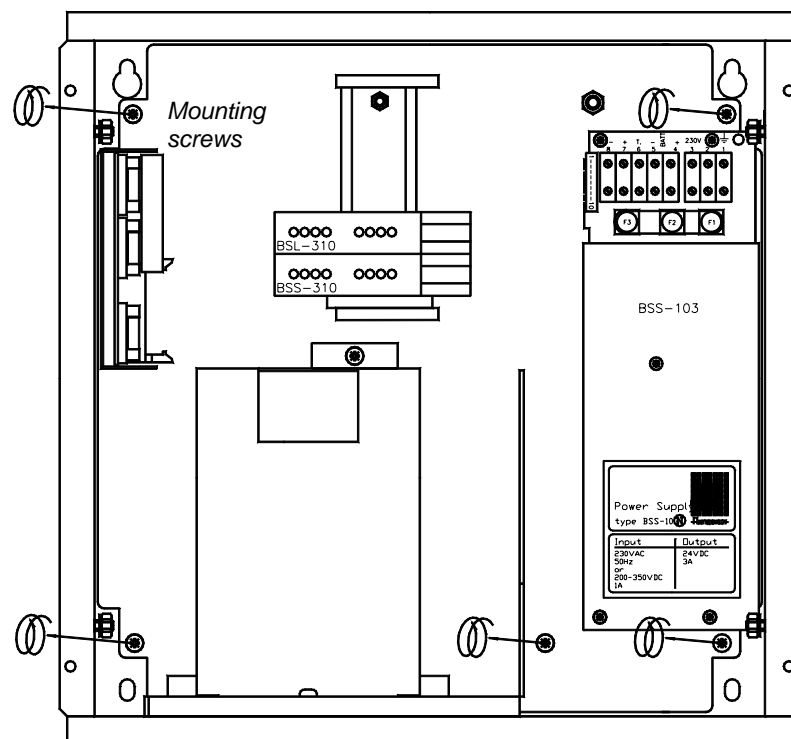

2.6.3 Flush Mounting Before Construction of the Wall

If a flush mounting is planned before construction of the wall, the cabinet - *without* the inside units and front panel - can be used as a casting frame.

WARNING:

To avoid deformation, make sure that the cabinet is supported inside before concreting.

2.6.4 Cut Out Dimensions

The illustration below shows the cabinet's cut out dimensions. The dimensions given include space for the cover frame, but not for the required free space of minimum 50 mm on the top / bottom of the cabinet.

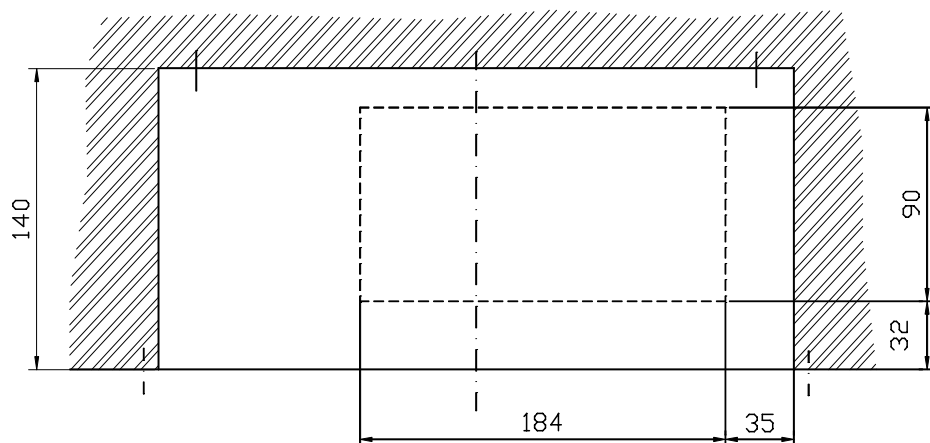
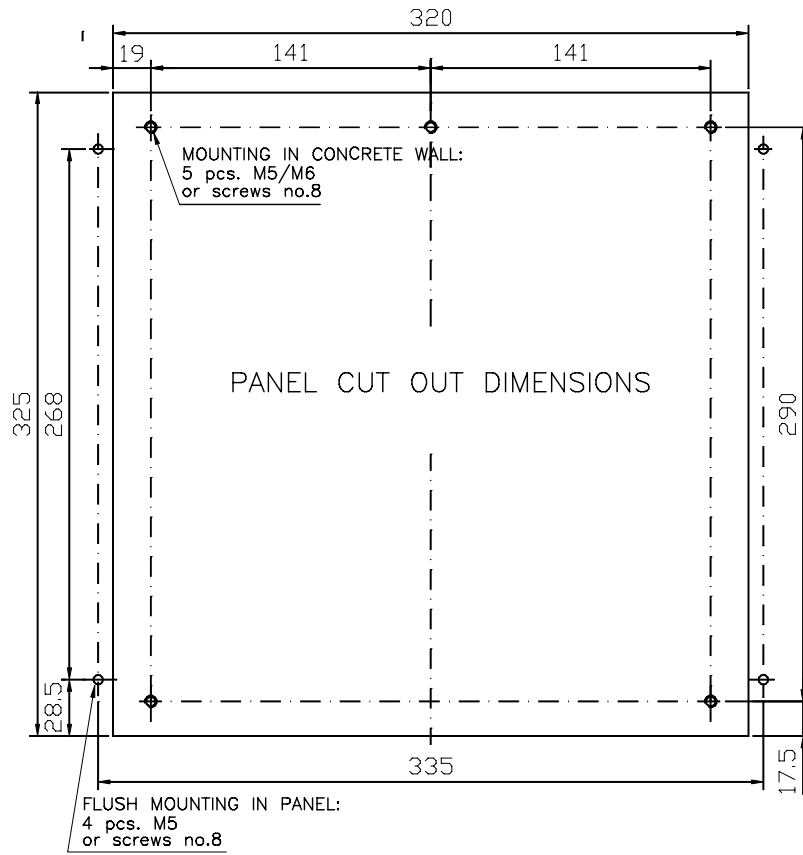

2.6.5 Mounting the Cabinet

The cabinet has 4 mounting holes located on the left and right flange.

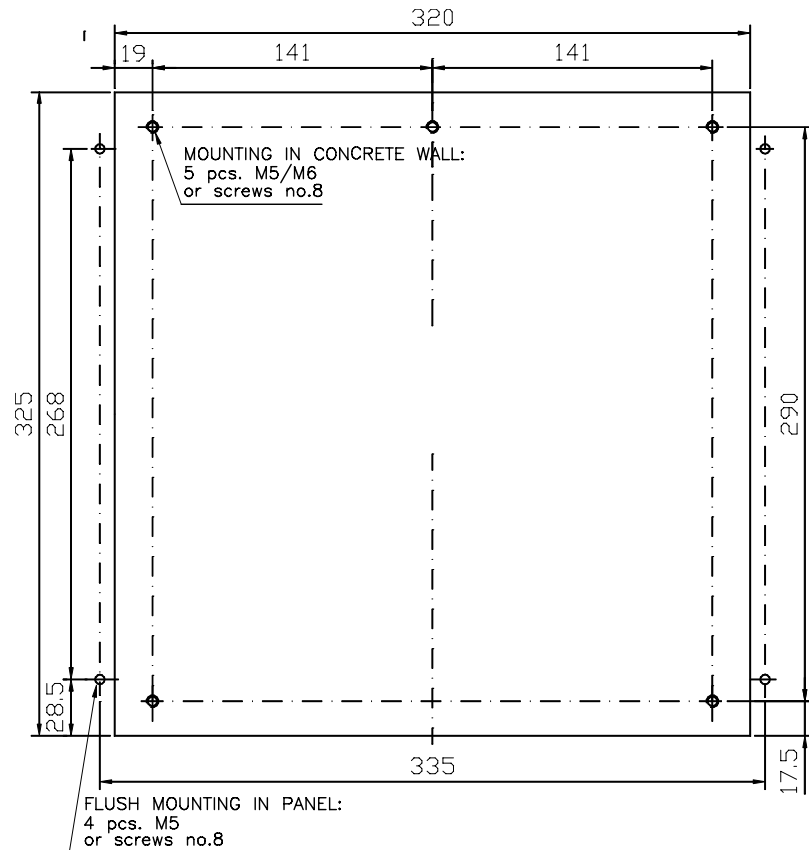

Consult the illustration above, and do the following:

- Mark and drill all the holes according to the illustration.
- Place the cabinet into the wall and fasten the 4 screws.

2.6.6 Reassembling the Mounting Plate

- Reassemble the mounting plate carefully into its position inside the cabinet.
- Tighten the screws.

2.6.7 Cable Inlets / Outlets

- Feed all the cables into the cabinet from the rear through the suitable cable inlets (refer to chapter 2.5.3).

2.6.8 Cable Connections

- For detailed information on cable connections, refer to chapter 3 in this manual.

2.6.9 Mounting the Batteries

- Follow the instructions in chapter 2.5.5.

2.6.10 Reassembling the Front Panel

- Follow the instructions in chapter 2.5.6.

2.6.11 Mounting Several Panels in a 19" Rack

Rack mounting requires a free space of minimum 50 mm on the top / bottom of the cabinet to be able to open and close the front panel.

For this purpose, a 19" mounting plate can be used (UW-1459).

3. Internal Cable Connections

3.1 Introduction

The Fire Alarm Control Panel / Controller is customized according to each specific delivery. Most of the internal cabling is already done (see *Cable Connections - Overview*), as the control panel will always be delivered from the factory with the mandatory internal I/O modules; Power Module BSS-310 and the Communication Module BSL-310 installed.

In addition to a description of the location of the fuses and internal cable connections overview, this chapter covers the following:

- Connecting the Power Supply & Battery Charger
- Connecting the Battery
- Connecting the network cables (AUTROLON)
- Connections for Temperature Compensated Battery Charging Voltage (when external battery connection is used)

3.2 Before Connecting Cables



POWER OFF!

- Before connecting cables, make sure that the mains power is *not* connected.
- Remove the fuses F1 and F2 on the Power Supply (refer to illustration in the subsequent chapter).
Do not replace the fuses until commissioning of the system.

3.3 Location of Fuses

3.3.1 Fuses on Power Supply, BSS-103A/02



POWER OFF!

- Remove the fuses F1 and F2 on the Power Supply.
Do not replace the fuses until commissioning of the system.

Fuse No.	Size	Type	Slow/Fast	Protecting
F1	2 A	T2AH/250V AC	Slow (T)	Mains
F2	6,3 A	F6,3AH/250V AC	Fast (F)	Battery
F3	1 A	T1AL/250V AC	Slow (T)	External 24V DC

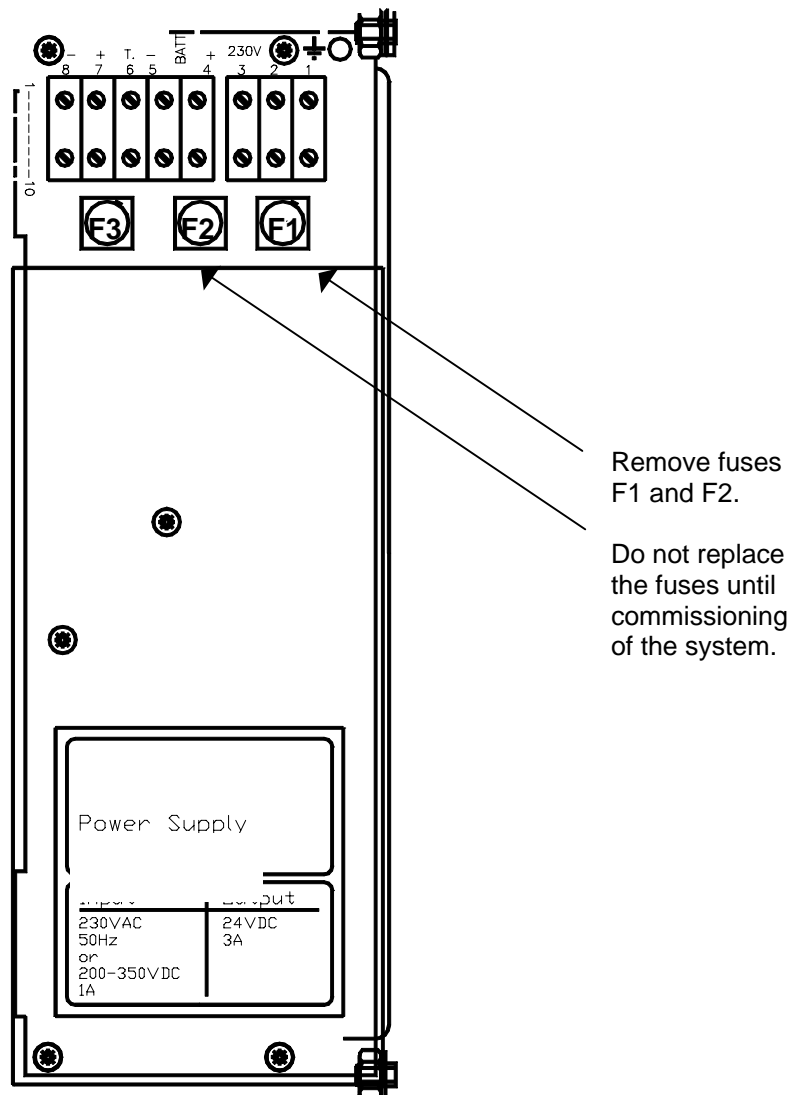

3.3.2 Fuses on Connection Module, BSF-310B

Fuse No.	Size	Type	Slow/Fast	Protecting
F1	3,15 A	T3,15AL/250V AC	Slow (T)	Charger Circuit
F2	4,0 A	T4AL/250V AC	Slow (T)	Battery
F3	2 A	F2AL/250V AC	Fast (F)	I/O Power
F4	2,5 A	T2,5AL/250V AC	Slow (T)	Battery / External 24V

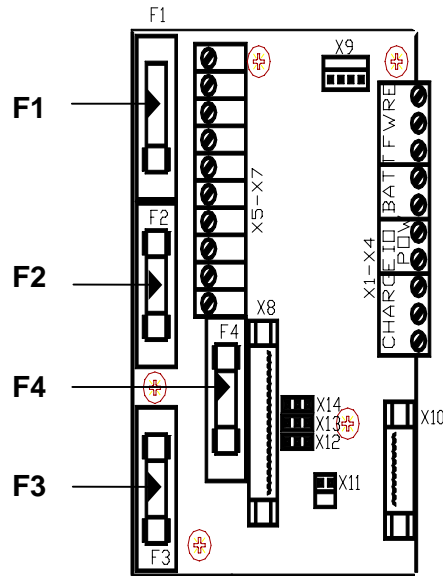

3.4 Shielding and Earthing

3.4.1 Introduction

Due to requirements in EN54 and generic EMC-requirements, it is very important to keep in mind how to make earthing and shielding of cables when installing.

3.4.2 Definitions

Protective Earth 	Termination point to the external protective earth. In AutoSafe this is the connection at the BSS-103A/02 block terminal (terminal 1).
Protective Earth to Cabinet	Main earth connection which ensures that the cabinet always is connected to earth. Note: Must not be removed or unscrewed.
Chassis	Electrical connection to the steel cabinet. A screw on the rear mounting plate (up left to the Power Supply) is provided for this. This is in turn connected to the Protective Earth for human protection and earthing.
Shield	Termination point for the shielding of cables, where provided.
0V_BAT	Reference point for the battery circuit (isolated from earth/chassis).

Detail drawing of Power Supply / upper part of Fire Alarm Control Panel / Controller

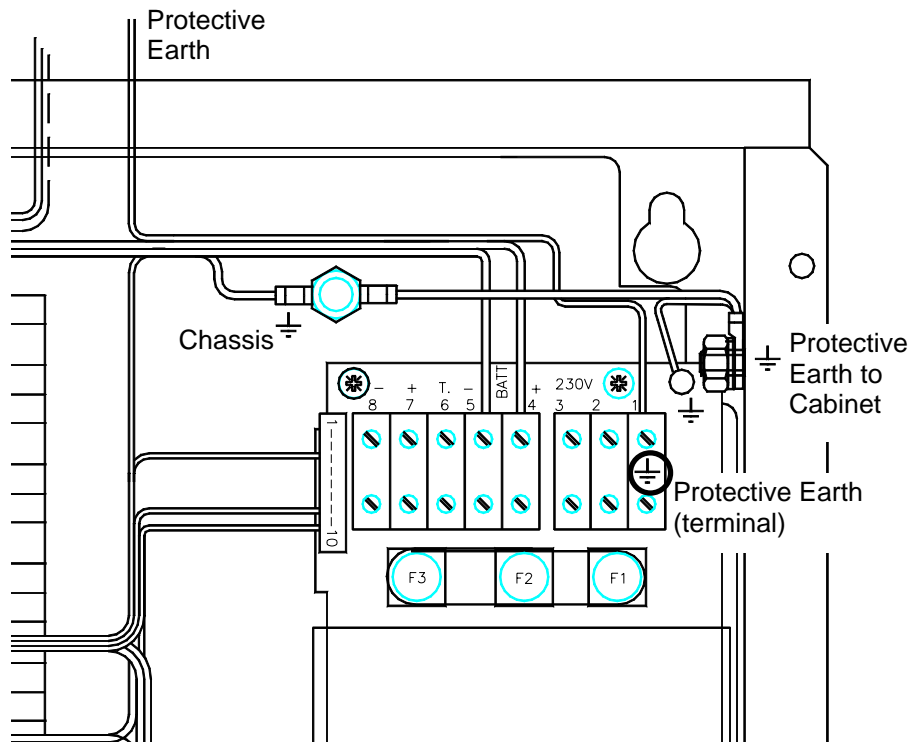

3.5 Power Supply and Battery Connections

3.5.1 Connecting 230 VAC to Power Supply BSS-103A/02

NOTE!

The illustration below shows an overview of the mains connection (230 VAC) to the Power Supply BSS-103A/02. The connection of mains power is done during commissioning. Until then, do not connect the mains power.

Schematic outline inside cabinet - Front view

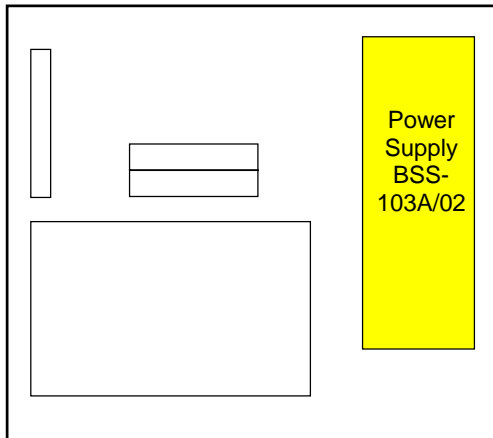

In the fixed mains wiring to the panel a two-pole disconnect device must be provided to disconnect the equipment from the power supply when servicing is required. Normally, this switch is a two-pole automatic fuse located in the fuse terminal box at the premises. This fuse location must be marked "Fire Alarm System".

The isolation of the mains wiring must be of either:
 inflammability class V2
 or
 the wiring has to be fixed to the cabinet separated from all other cables

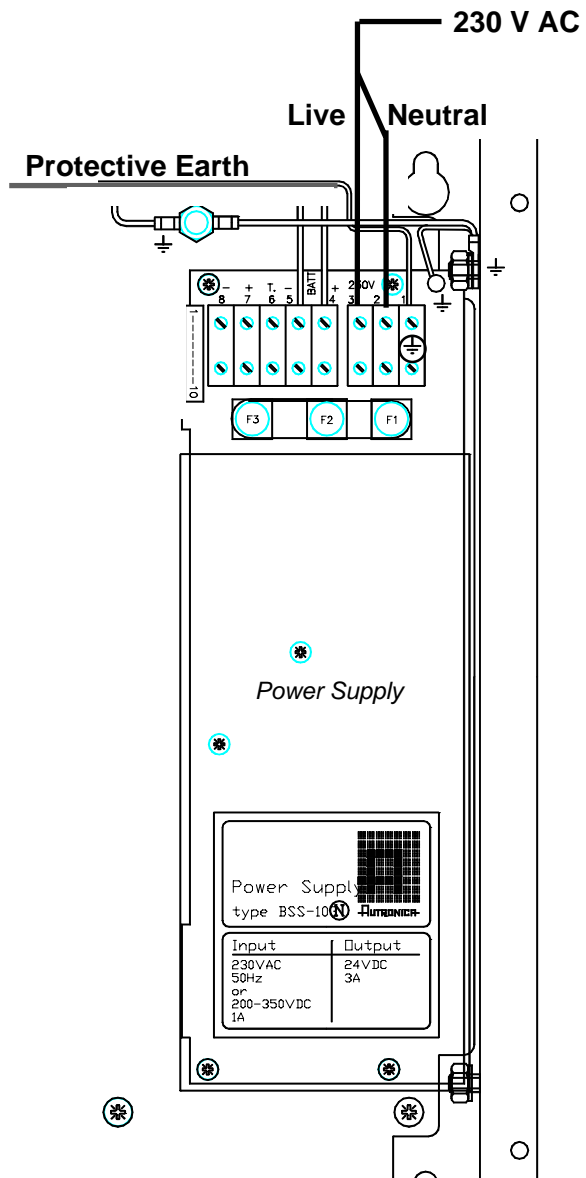

3.5.2 Connecting the Batteries to Connection Module and Power Supply

Schematic outline inside cabinet - Front view

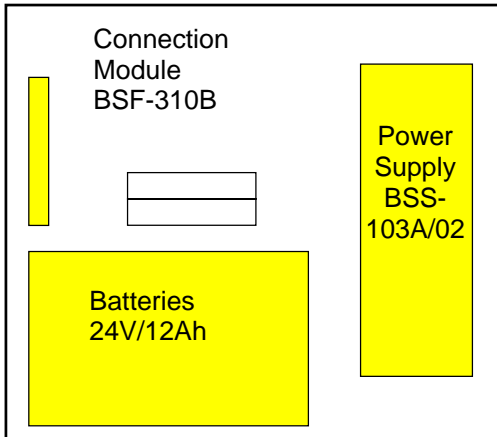

NOTE!

The illustration below gives an overview of the connections from the Connection Module to the Power Supply and to the batteries.

The connection of the batteries is done during commissioning. Until then, do not connect the batteries.

If the cabinet is to be placed in an environment with high humidity, an appropriate type of grease should be applied on the battery poles to avoid possible development of verdigris.

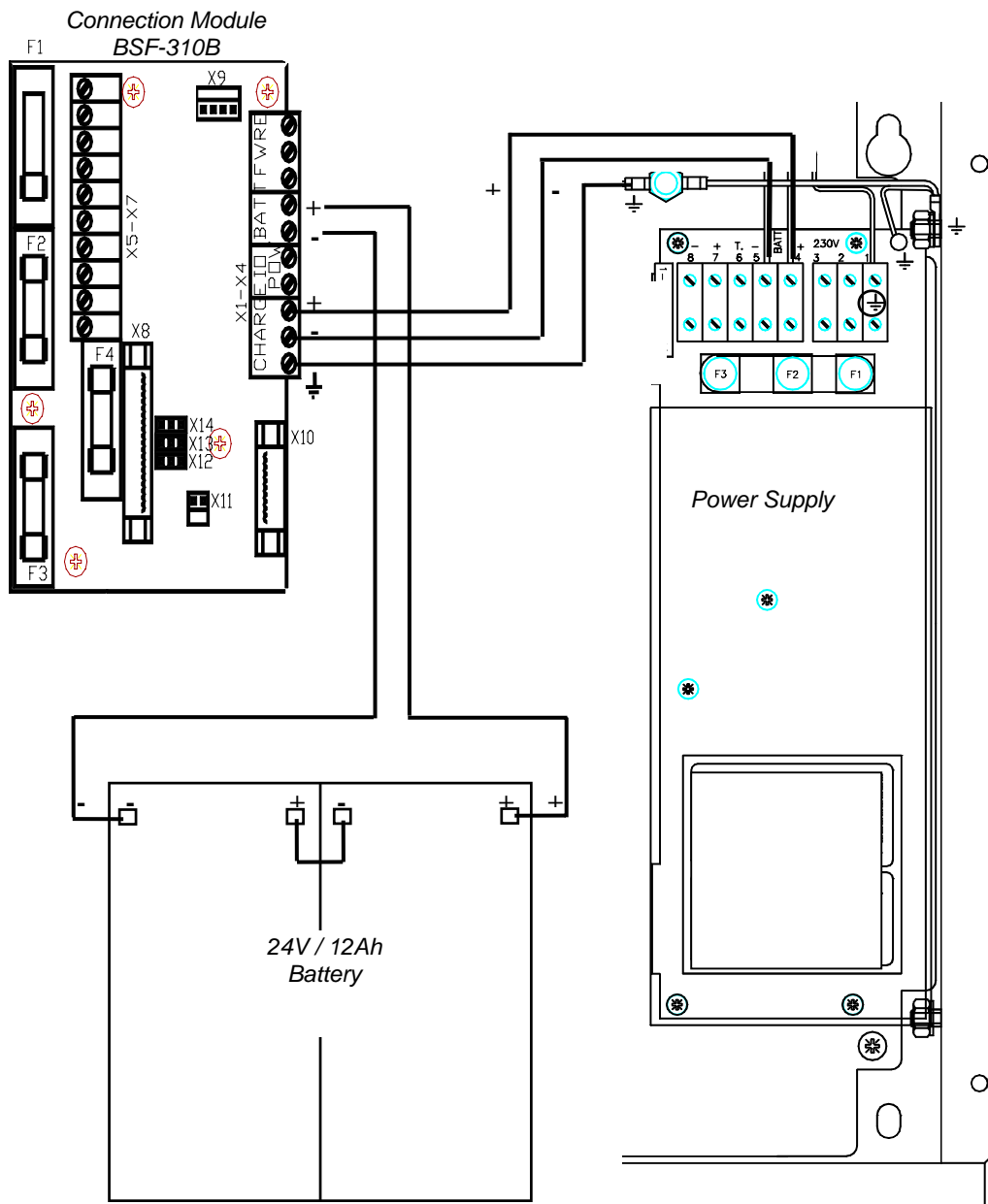

3.6 Connecting the Network Cables (AUTROLON)

3.6.1 External AUTROLON Cables

Note that the polarity of the external AUTROLON cables has no importance. Likewise, incoming and outgoing external AUTROLON cables can be freely connected to either LON-A or LON-B (see drawing on next page). For documentation purposes, however, we recommend that output is connected to A and input is connected to B.

In high-current environments (power plants, electrical machinery etc.) it is recommended that shielded cable is used. In this case, the shielding of the cable stubs between each cabinet should only be connected at one end to avoid ground loops. If high-frequency noise is expected (>10MHz), then both ends should be connected. This may be present close to radio transmitting equipment or similar.

3.6.2 Internal AUTROLON Cable

The internal AUTROLON cable is connected between the Connection Module BSF-310B and the LON Interface Board EAU-310 (see drawings below and on next page).

NOTE:

Make sure that the connector on each side is mated correct and is connected to all pins on the 4-pin terminal, and that the wires point downwards on the BSF-310B board, and inwards on the EAU-310 board.

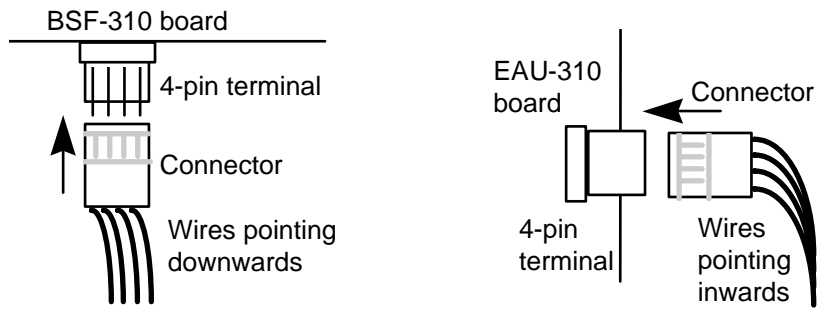

3.7 Internal Cable Connections - Overview

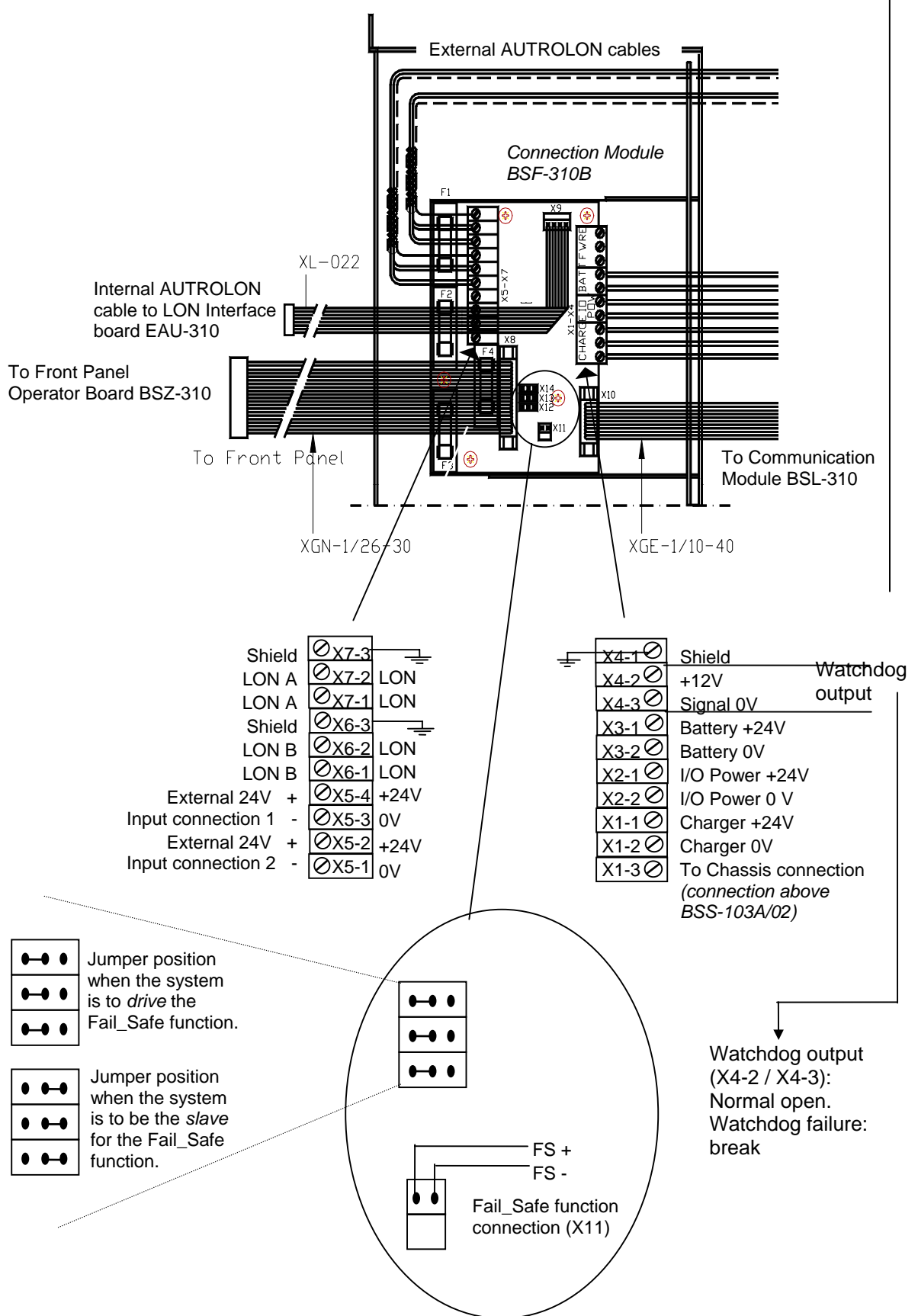

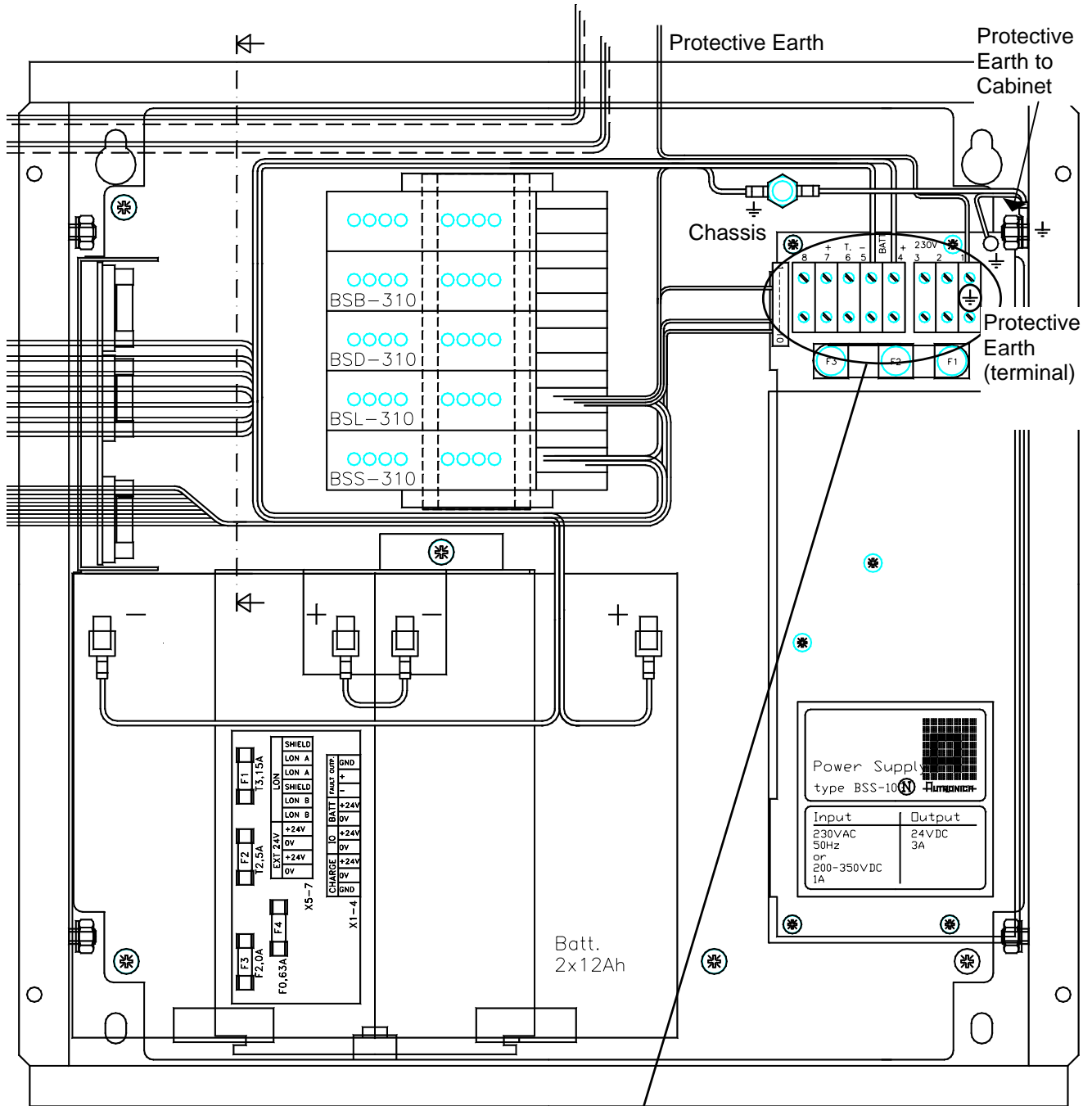

NOTE:

The following internal cable connections are already done when the product leaves the factory:

Power Module BSS-310: A small ribbon cable is used between the Power Module and the Power Supply BSS-103A/02.

Communication Module BSL-310: Two small ribbon cables are used.

One cable is used to interconnect the Communication Module and the Connection Module BSF-310B.

The other cable is used to interconnect the Communication Module and the Power Supply BSS-103A/02.

Screw Terminals on Power Supply BSS-103A/02

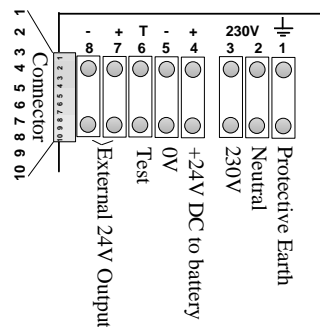

3.8 Connections for Temperature Compensated Battery Charging Voltage

3.8.1 Introduction

The Power Supply BSS-103A/02 in the Fire Alarm Control Panel BS-310/320 / Controller BC-320 is provided with a temperature sensor for temperature compensated battery charging voltage.

The internal connections to the sensor is already done when the product leaves the factory. The cable with the sensor has to be taped to the battery cover bracket. If a solution with external battery connection is used, the temperature sensor must be removed and a longer cable from an external battery cabinet must be attached to this connection (refer to next chapter).

AutroSafe cabinet

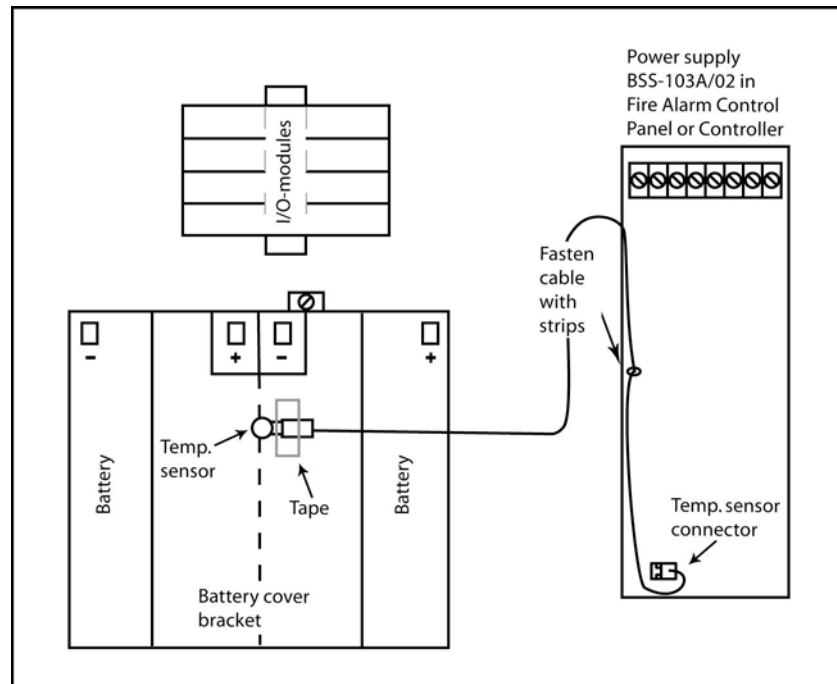

Fix the temperature sensor to the battery cover bracket with electrical tape.

3.8.2 Connecting the Cable to External Temperature Sensor

When a solution with external battery connection is used, the sensor must be removed from the Power Supply BSS-103A/02. A 3m cable must then be connected between the Power Supply BSS-103A/02 in the Fire Alarm Control Panel / Controller and the external temperature sensor mounted on a connector in the Battery Cabinet SY-310.

The cable for this purpose is delivered with the battery cabinet. For information on cable connections, consult the illustrations below.

- Remove the front cover on the Power Supply BSS-103A/02 (in the Fire Alarm Control Panel / Controller).

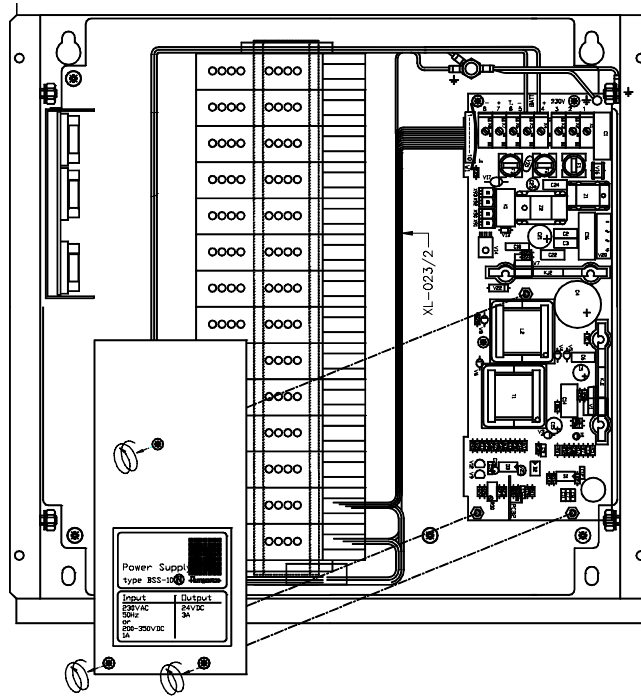

- Remove the temperature sensor.

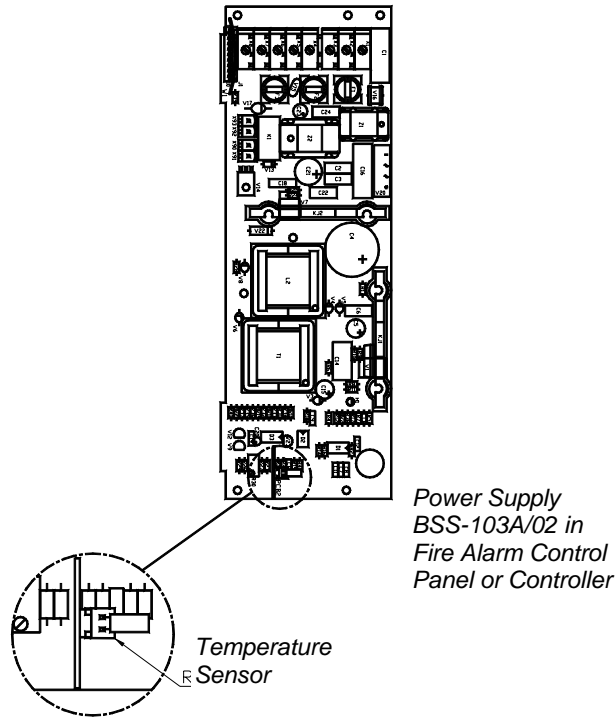

- Connect the cable from the Battery Cabinet to the connector on the Power Supply BSS-103A/02.

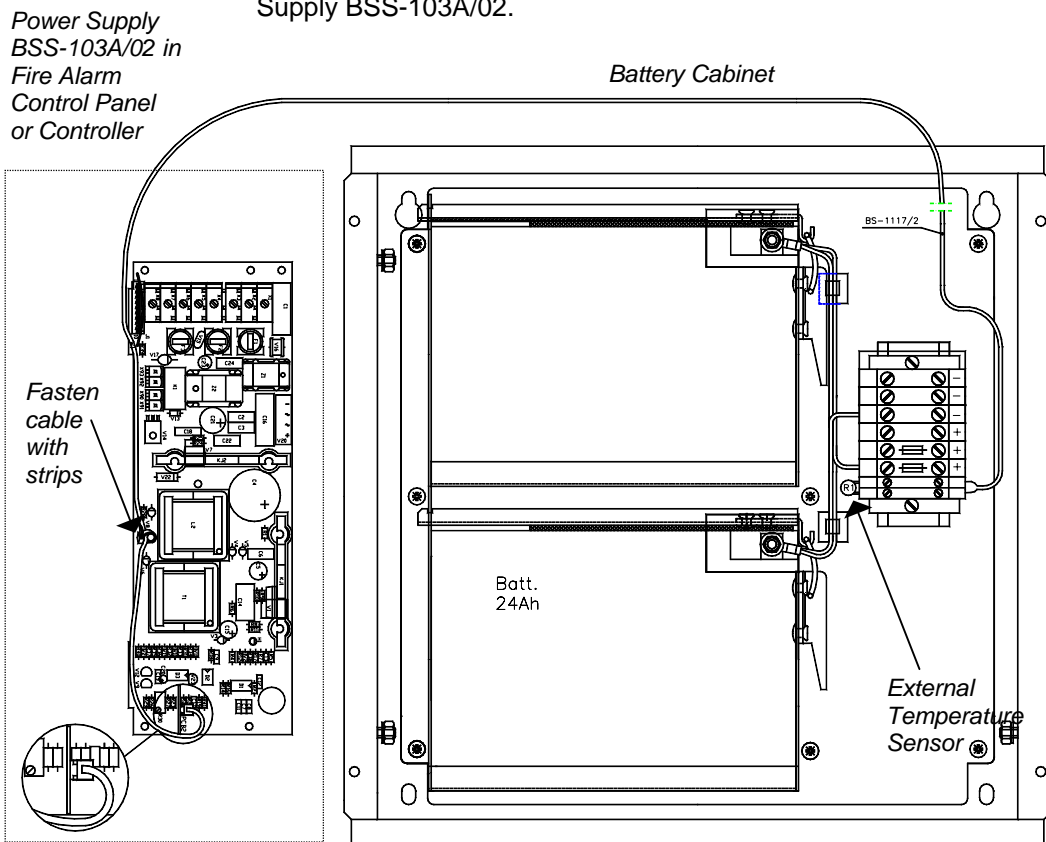

- Reassemble the front cover on the Power Supply BS-103/01.

4. Installing I/O Modules

4.1 Introduction

This chapter provides information on the mounting and removal of I/O modules.

Note that the internal *Power Module (BSS-310)* and the *Communication Module (BSL-310)* are already mounted in a fixed position when the product leaves the factory (refer to 1.5).

4.2 Front View of I/O Module

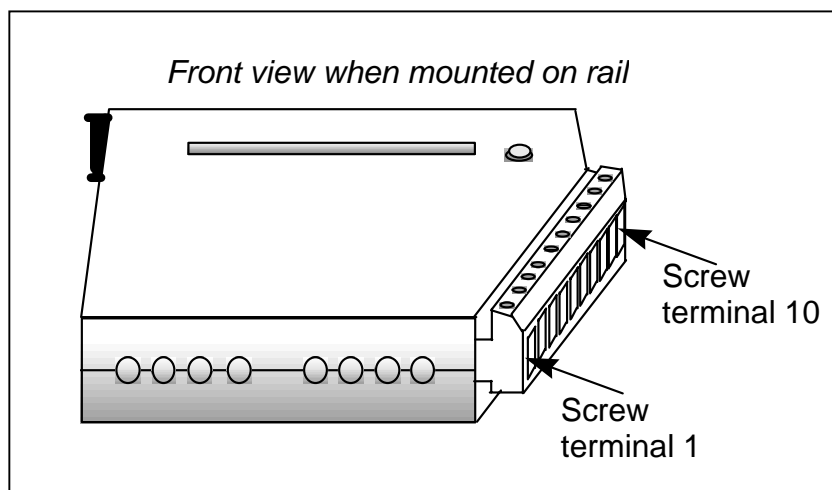

4.3 Mounting / Removing I/O Modules

4.3.1 General

Note! Make sure the mains power is OFF!

Note: The Power Module (BSS-310) must always be mounted first on the rail - at the bottom - before any other modules. The Communication Module (BSL-310) is then mounted on top of the Power Module.

All other modules can be mounted in arbitrary order on top of these two modules.

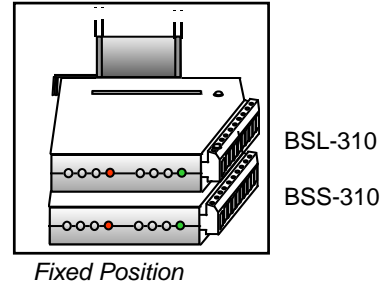

When the system is to be configured at a later point, note that the AutoSafe Configuration Tool graphically shows the first module on the top of the figure and the following in descending order. This is opposite to the physical mounting, and must be taken into consideration when configuring the system. Also note that the configuration tool does not show the BSS-310 and BSL-310.

4.3.2 Mounting

The connection block on the I/O module must be pointing to the right when the module is to be inserted.

- Snap the right side of the fastener onto the mounting rail (1), then press the module slightly inwards (2) until the left side fastens.
- Then, carefully press the module downwards as far as possible. Make sure that the module is properly connected to the module below.

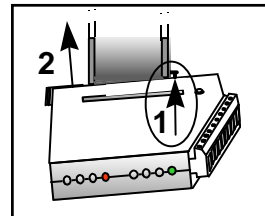

4.3.3 Removing

- Unplug the connection block.
- Use a screwdriver to carefully lift the topmost module upwards (1) until the connector between the modules is free.
- Use the screwdriver to slightly bend the left side of the fastener *towards left* (2) until it loosens, then remove (3) the module.
- If necessary, continue removing the next one in the same way.

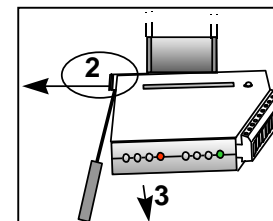
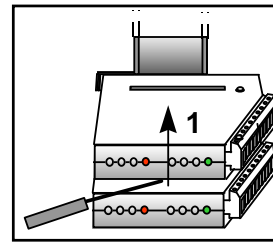

4.3.4 Before Connecting Cables

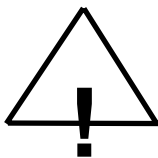

POWER OFF!

- Before connecting cables, make sure that the mains power is *not* connected.
- Remove the fuses F1 and F2 on the Power Supply (refer to illustration in chapter 3.3.1). Do not replace the fuses until commissioning of the system.

4.4 Data Sheets - I/O Modules

The AutoSafe User Documentation provides data sheets for I/O modules, including a short description of the I/O module, its application, plus technical specifications and cabling. The subsequent chapters in this handbook provide necessary information on connections, screw terminals and signals.

- Power Module, BSS-310
- Communication Module, BSL-310
- Loop Driver Module, BSD-310 / BSD-311
- Output Module, monitored, BSB-310
- Output Module, BSJ-310
- Input Module, monitored, BSE-310
- Input Module, BSE-320

4.5 Power Module, BSS-310

The I/O module has the following connections:

Screw Terminal no.	Signal
1	+24 V Input
2	+24 V Input
3	0 V Input
4	0 V Input
5	Chassis
6	Chassis
7	Not in use
8	Not in use
9	Not in use
10	Not in use

The module has two green indicators;

- Right green indicator (H1) - the presence of 24V DC
- Left green indicator (H2) - the presence of 5V DC

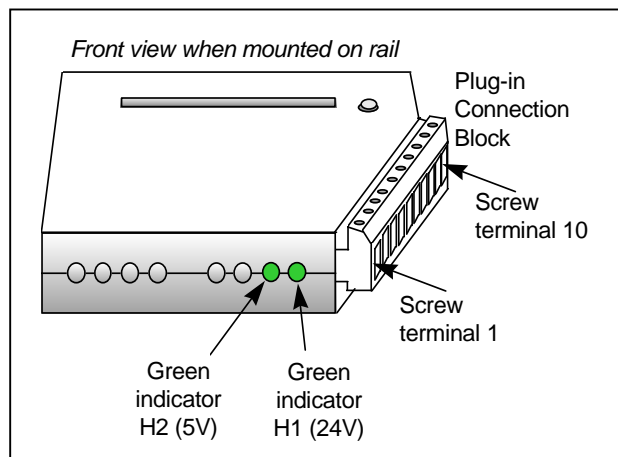

Schematics

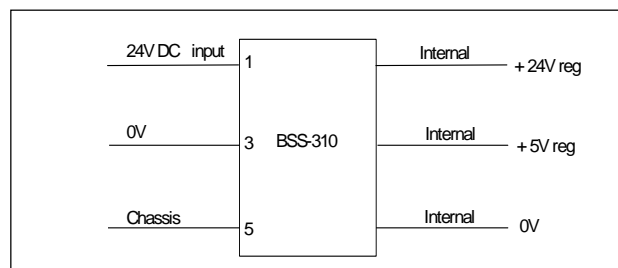
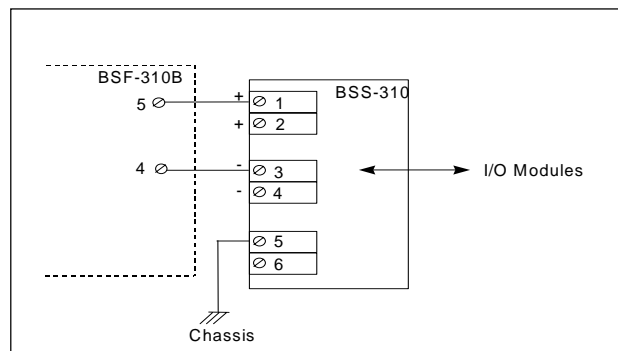

4.6 Communication Module, BSL-310

Connector on ribbon Cable 1 To Connection Module BSF-310B	Signal
1	INT
2	RS_GND
3	TX
4	RS_GND
5	N.C. (GND)
6	RS_GND
7	RX
8	RS_GND
9	CTS
10	RS_GND

Connector on ribbon Cable 2 To Power Module BSS-103A/02	Signal
1	TEST
2	N.C.
3	N.C. GND
4	MAINS_OK
5	N.C.
6	APPLY_LOAD

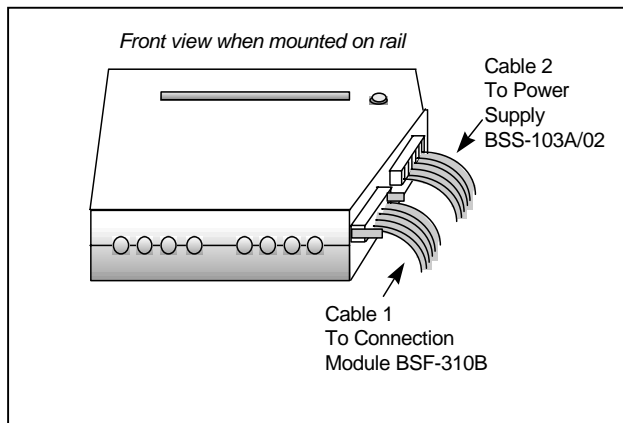

Schematics

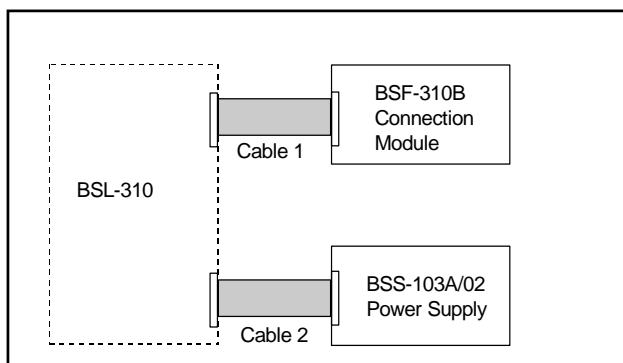

4.7 Loop Driver Module, BSD-310 / BSD-311

Screw Terminal no.	Signal
1	OUT + (+24V)
2	OUT - (0V)
3	Shield
4	IN +
5	IN -
6	Shield
7	F/S +
8	F/S -
9	Chassis
10	Chassis

- Green indicator, H5. Communication indicator that gives a pulsing green light during traffic.
- Red indicator, H1. Fail_Safe indicator that gives a steady red light if a communication failure occurs, i.e. the system does not respond to an alarm.

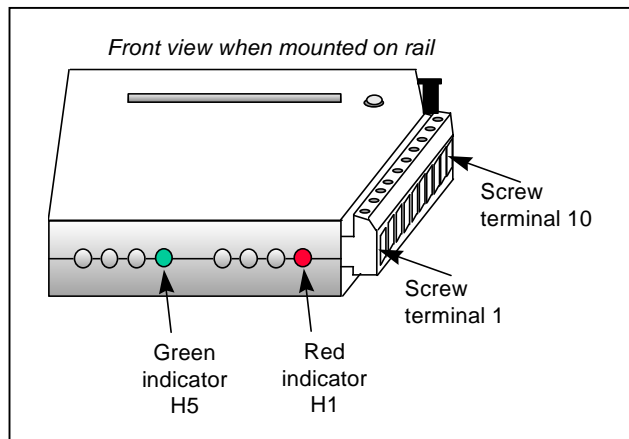

Schematics

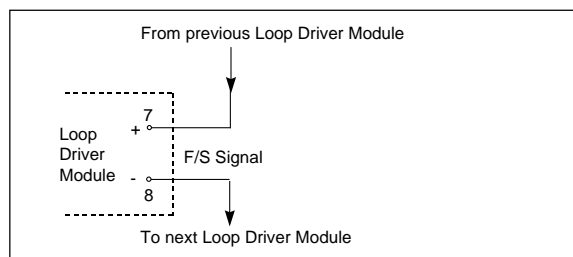
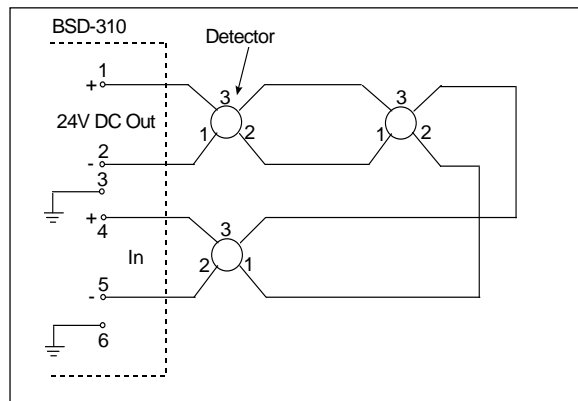

4.8 Output Module, Monitored, BSB-310

Screw Terminal no.	Signal
1	Output AK1 - (0V)
2	Output AK1 + (+24V)
3	Output AK2 - (0V)
4	Output AK2 + (+24V)
5	Output AK3 - (0V)
6	Output AK3 + (+24V)
7	Output AK4 - (0V)
8	Output AK4 + (+24V)
9	Input 24 VBAT
10	Input 0 VBAT

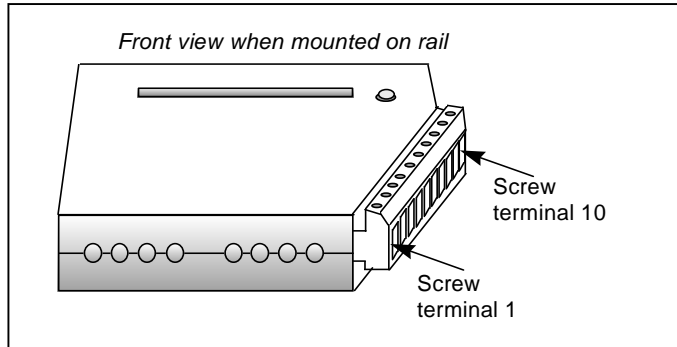

Schematics - Monitored Output

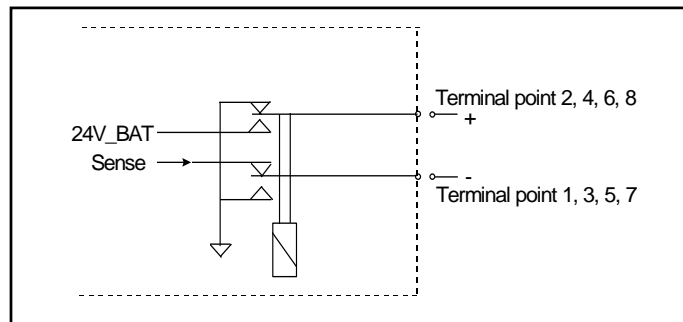

Schematics - Fault Warning Routing Equipment (FWRE) Output Output 4 only.

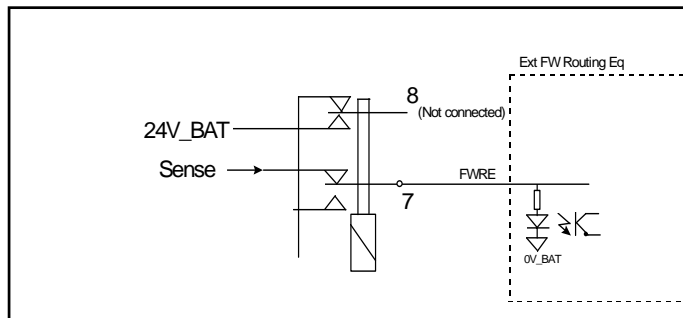

4.9 Output Module, BSJ-310

Screw Terminal no.	Signal
1	OC1
2	OC2
3	OC3
4	OC4
5	OC5
6	OC6
7	OC7
8	OC8
9	24 VBAT Output
10	Chassis

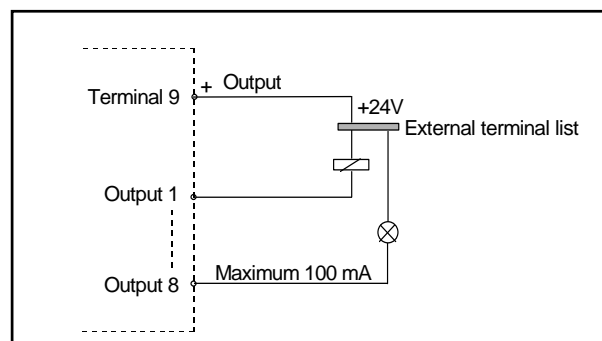
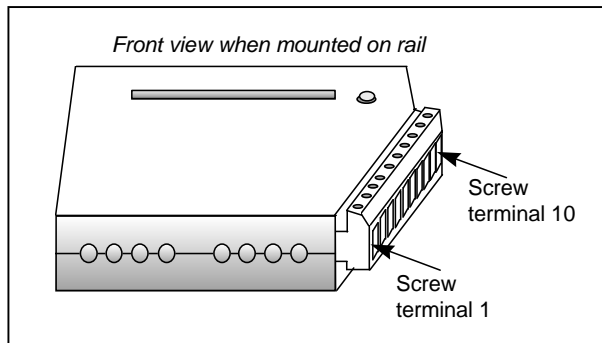

Schematics

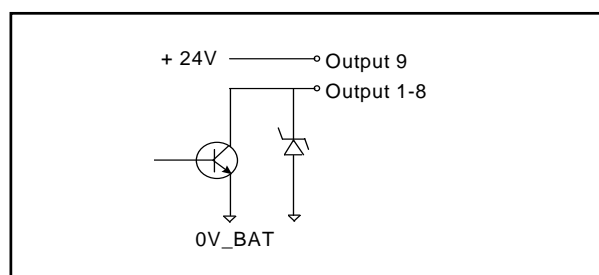

4.10 Input Module, Monitored, BSE-310

Screw Terminal no.	Signal
1	IN1 +
2	IN1 - (0V)
3	IN2 +
4	IN2 - (0V)
5	IN3 +
6	IN3 - (0V)
7	IN4 +
8	IN4 - (0V)
9	24 VBAT
10	0 VBAT

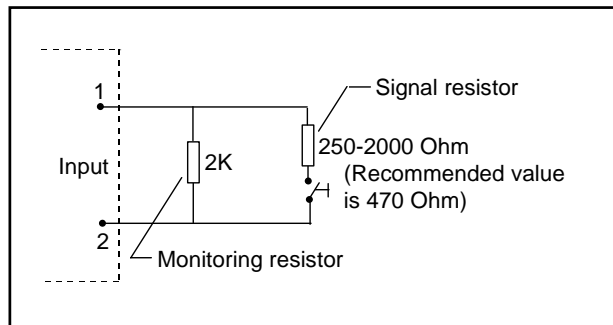
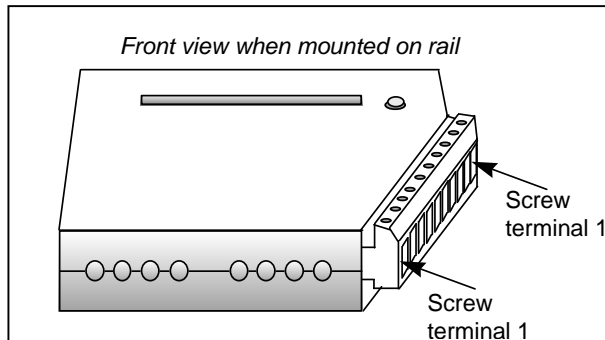

Schematics

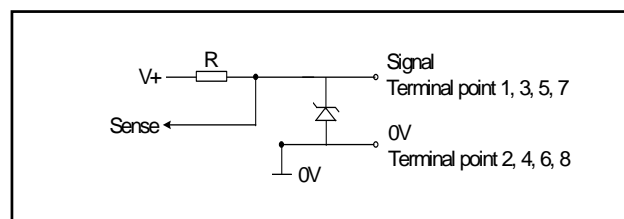

4.11 Input Module, BSE-320

Screw Terminal nr.	Signal
1	IN1
2	IN2
3	IN3
4	IN4
5	IN5
6	IN6
7	IN7
8	IN8
9	n.c.
10	INx-power supply Common source to all inputs (+)

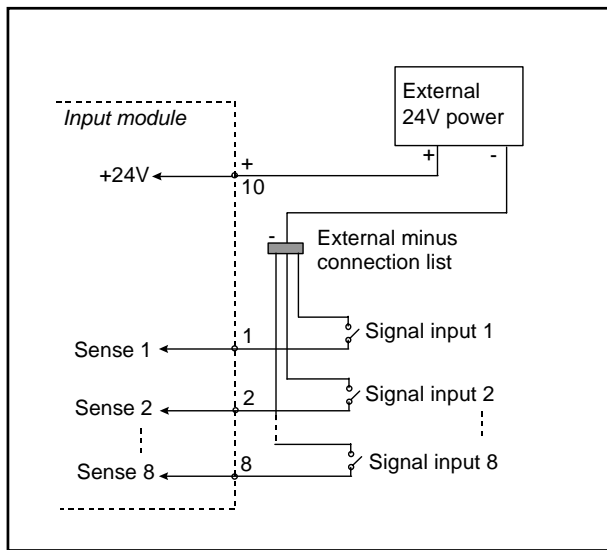
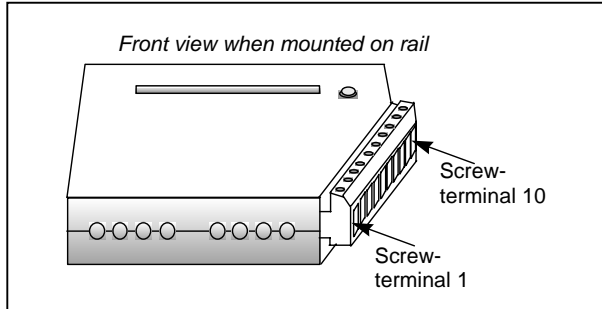

Schematics

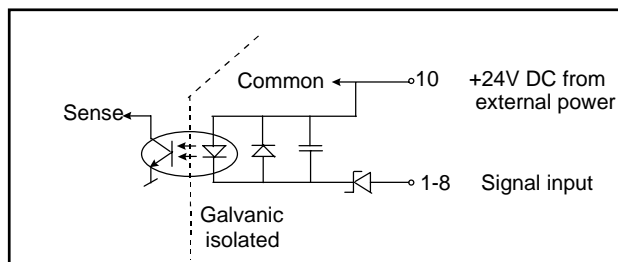

5. Connections to Detectors

Note: For information regarding guidelines for the installation and addressing of Loop Units (including detectors), refer to chapter 9. Here you will find descriptions of the different parameters used during configuration, including; Tag Names (TN; the text on the label placed on the socket), Production Numbers (PN) and Loop Sequence Index (LSI).

5.1 Connecting Detectors

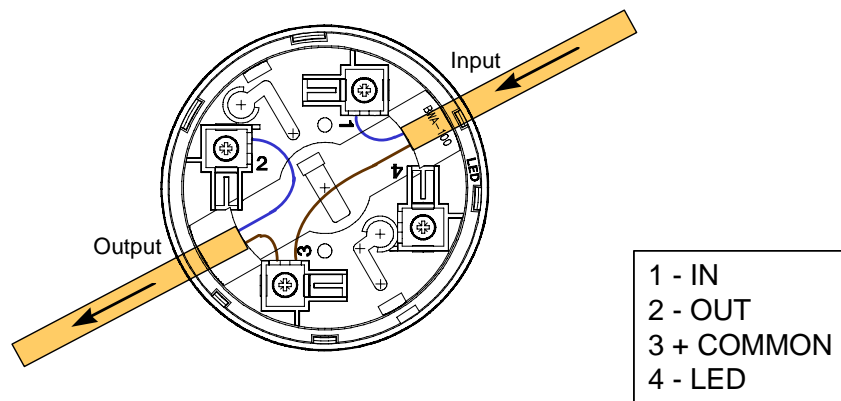
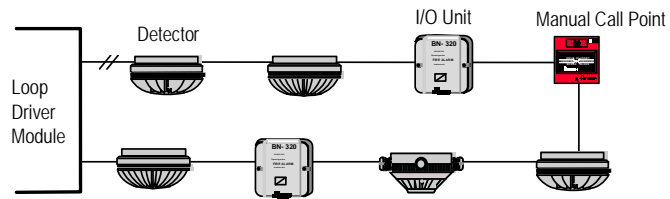

5.2 LED Connection on Detector

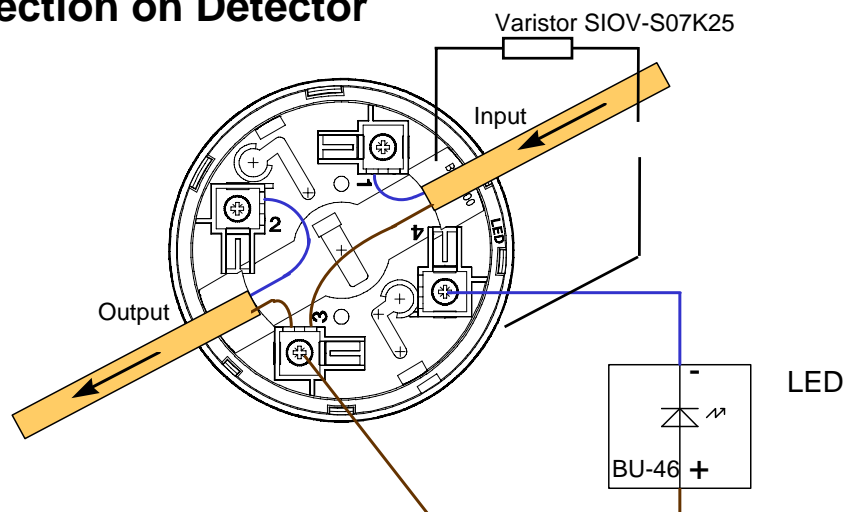

5.3 Connection of Branch-off

If necessary, a *branch-off* can be connected to a detector loop if the existing cable layout requires this, but this is *not* recommended, as the safety will be reduced.

To ensure a correct addressing of the detectors on a branch-off when configuring the system, *there can not be more than one branch-off per detector*. For safety reasons, the number of detectors on each branch-off must be kept to a minimum, as the detectors on a branch-off will not operate in case of a break or shortcircuit on the branch-off. The absolute maximum number of detectors on a branch-off (or an open loop) is 32.

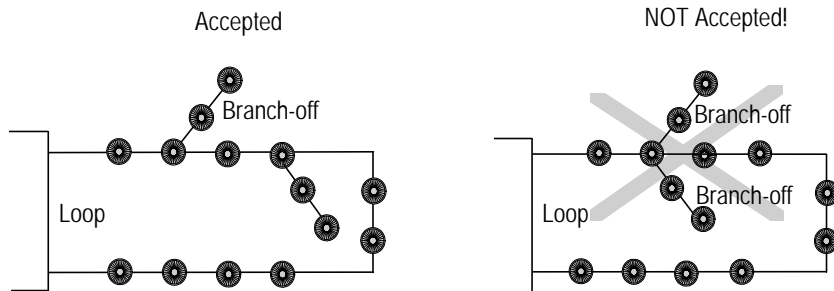

NOTE:
Always connect a branch-off to terminal 2 (-) and 3 (+).

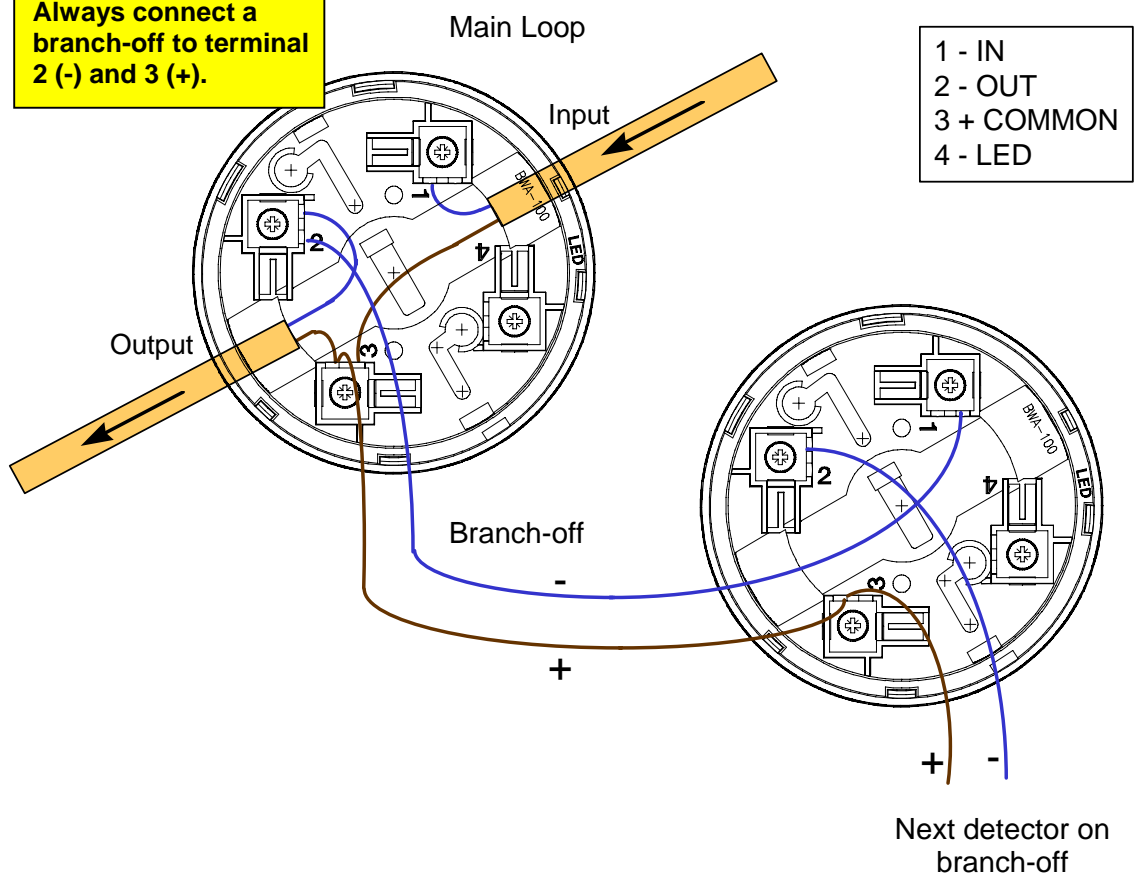

5.4 Detector Head / Base Alignment

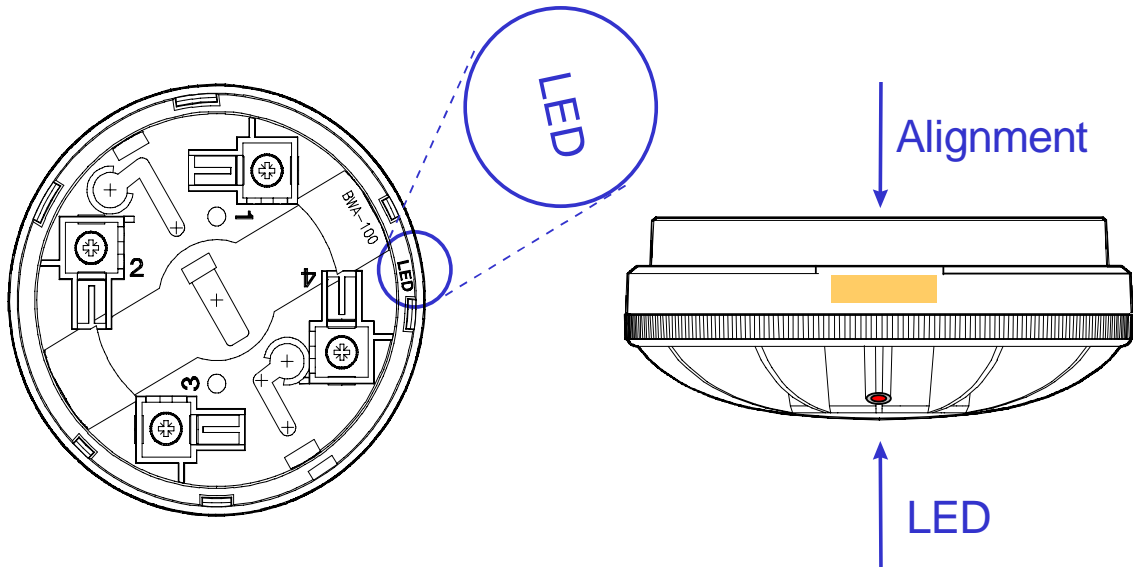

5.5 Detector Label

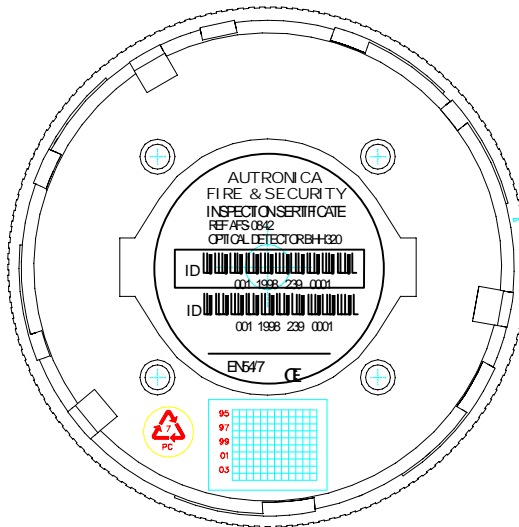

5.6 Detector Dust Covers

Autronica detectors are supplied with a dust cover. To avoid possible contamination of the detector chamber during installation, these should remain in place on the detector until commissioning is started.



6. Connections to Other Loop Units

6.1 Introduction

The following subsections show the connection of various Loop Units. For more detailed information on the Loop Units described in this chapter, please refer to data sheets and other relevant user documentation from Autronica Fire and Security AS.

6.2 Manual Call Points

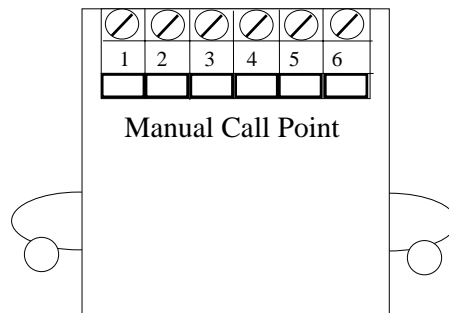
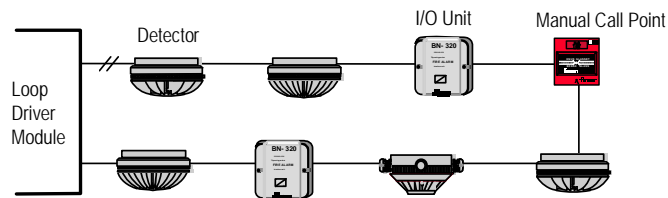

Connector on Manual Call Point	Wires on Loop
1	Pos (+) in
2	Pos (+) out
3	Neg (-) in
4	Neg (-) out
5	Internal connection
6	Internal connection

6.3 AutoSense 100 Aspirating Detector

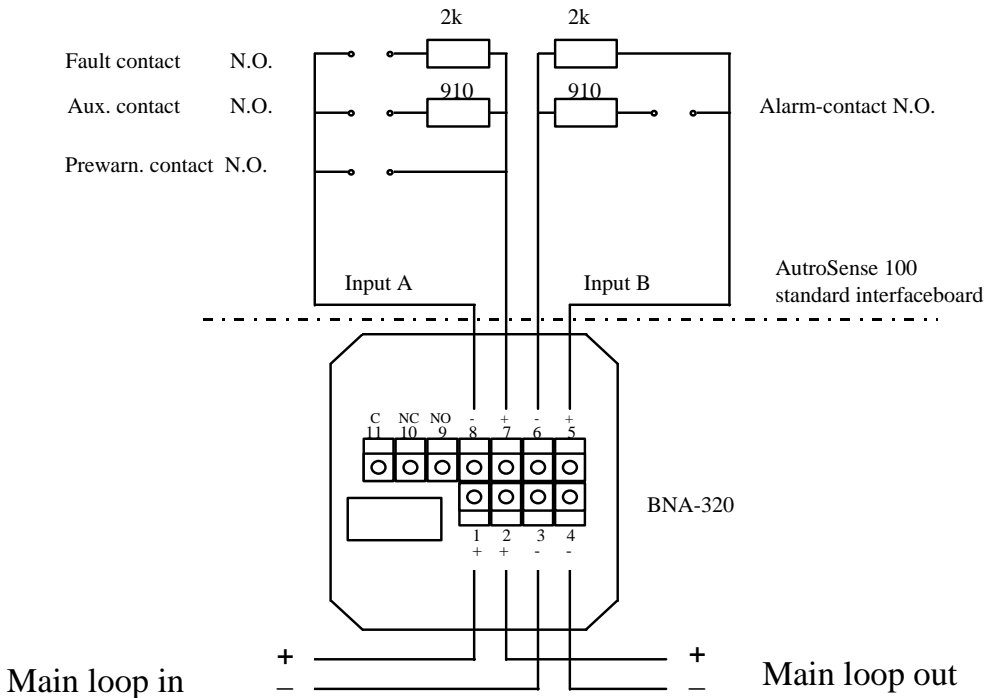
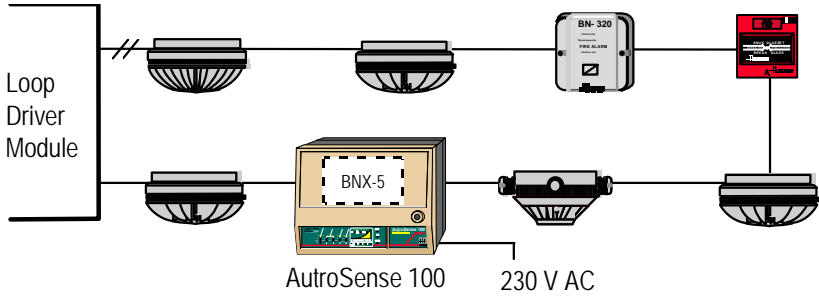

6.4 AutoSense 75 Aspirating Detector

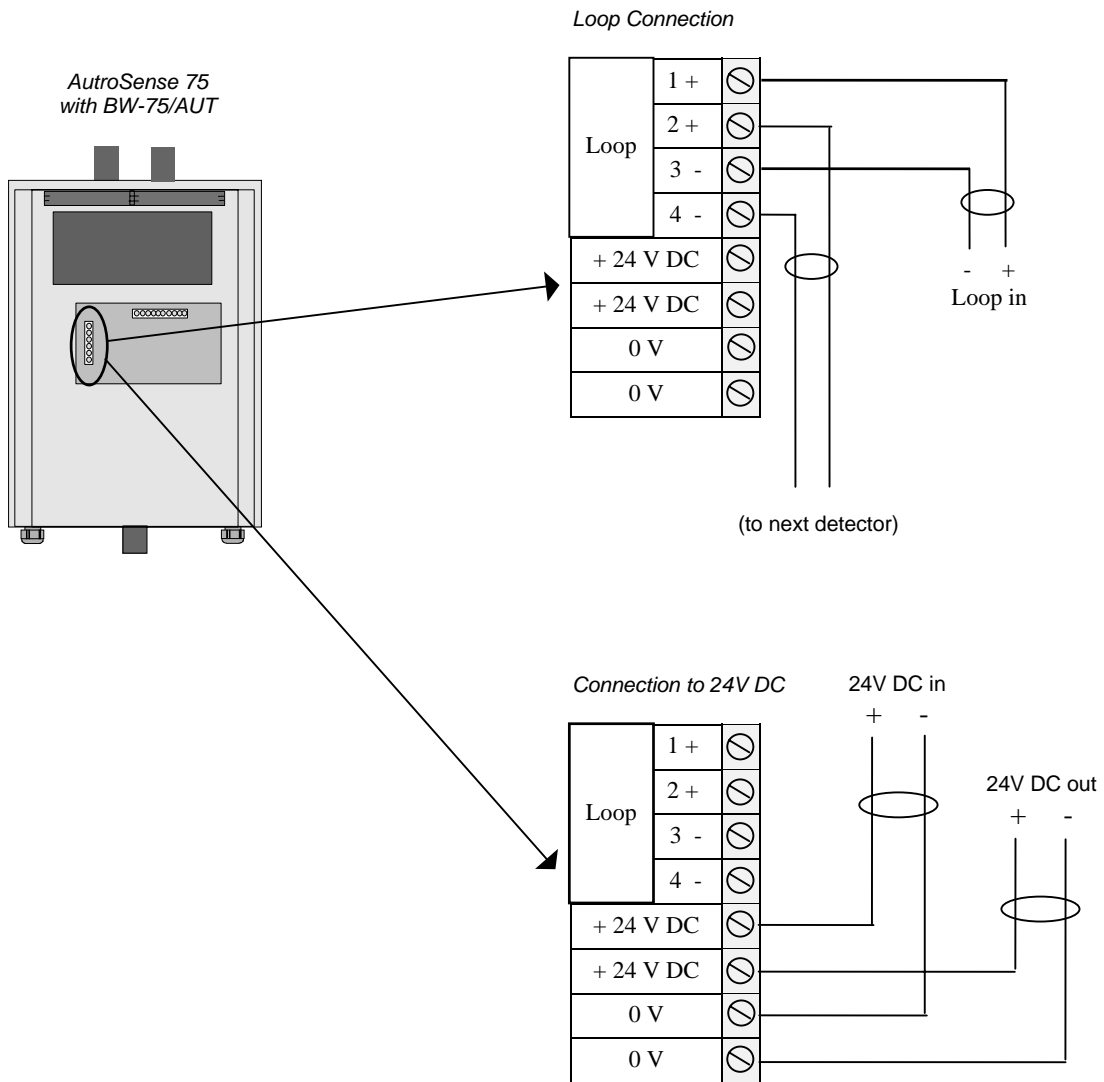
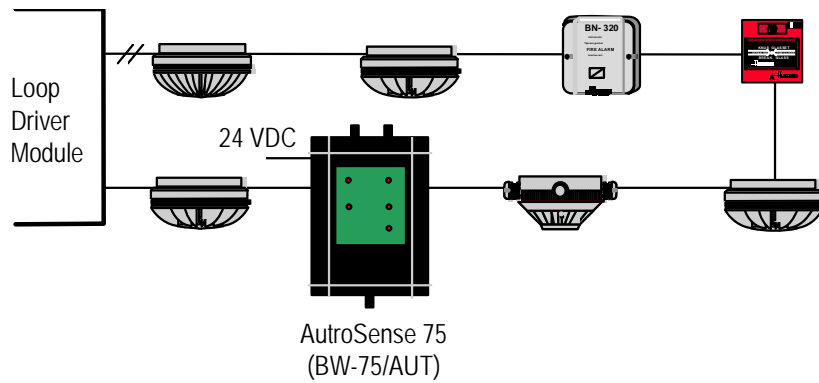

6.5 Flame Detection with AutoFlame

6.5.1 AutoFlame X33/1

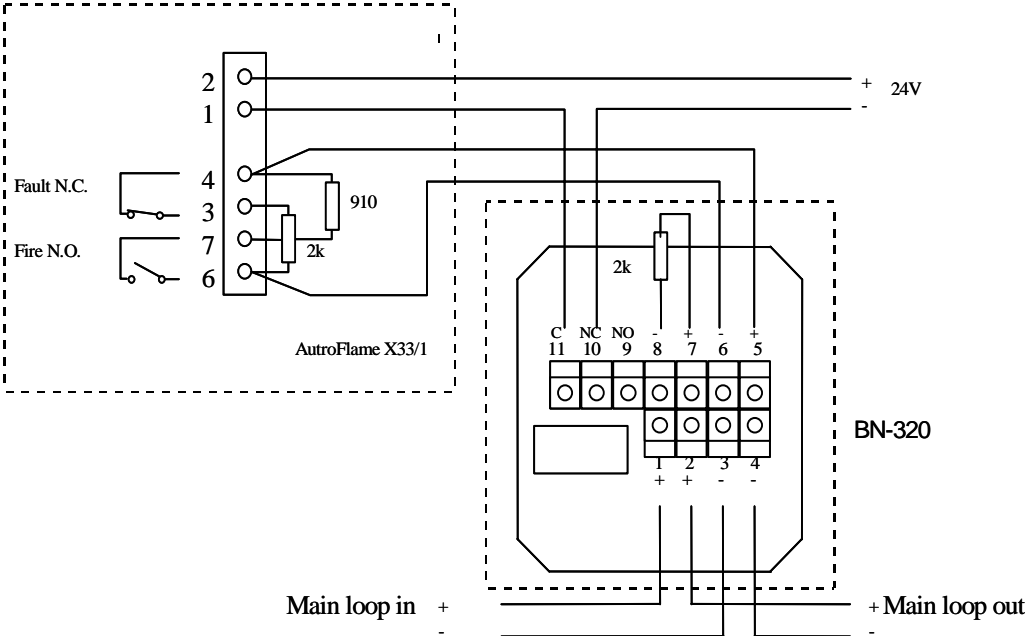
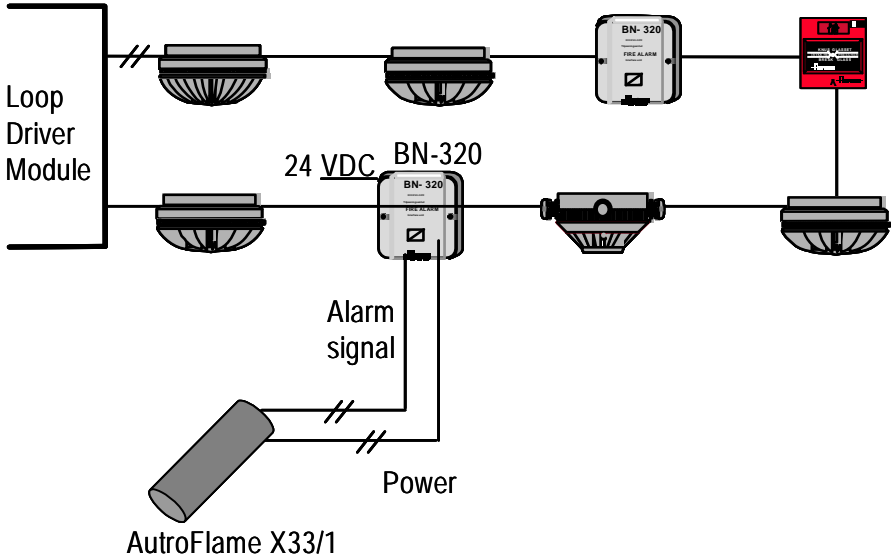

6.5.2 AutoFlame CCTV

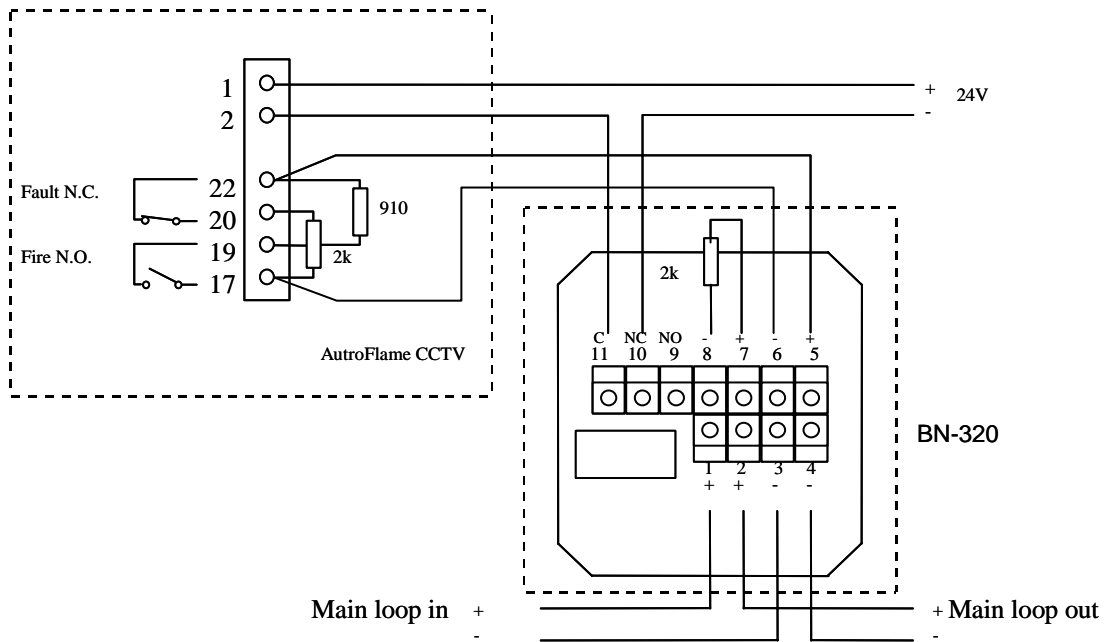
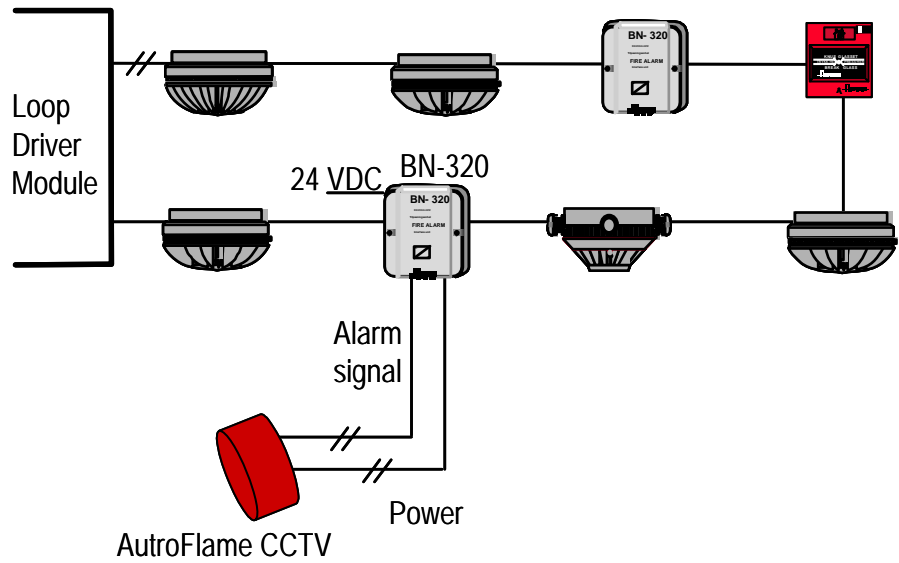

6.6 Line Detection with AutoBeam 100

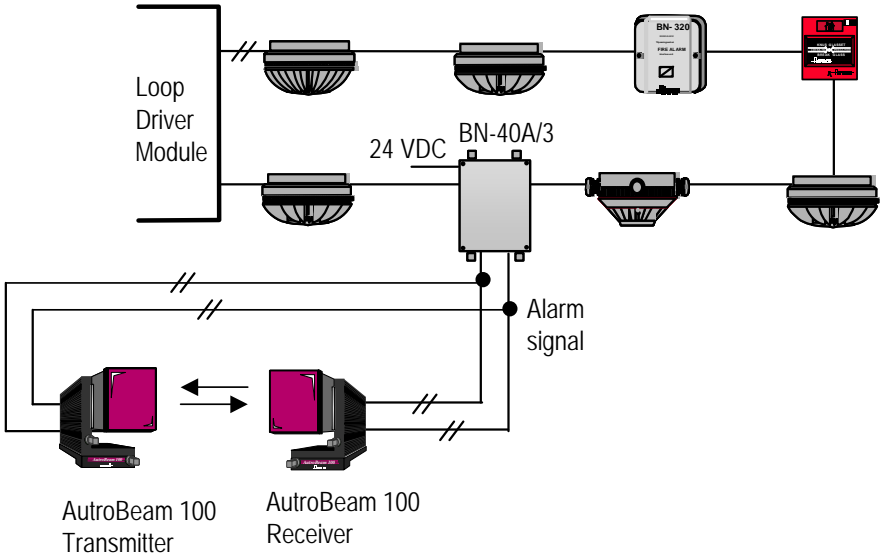

The interface unit BN-40A/3 should be installed close to the receiver (0,75m to 2m cable length).

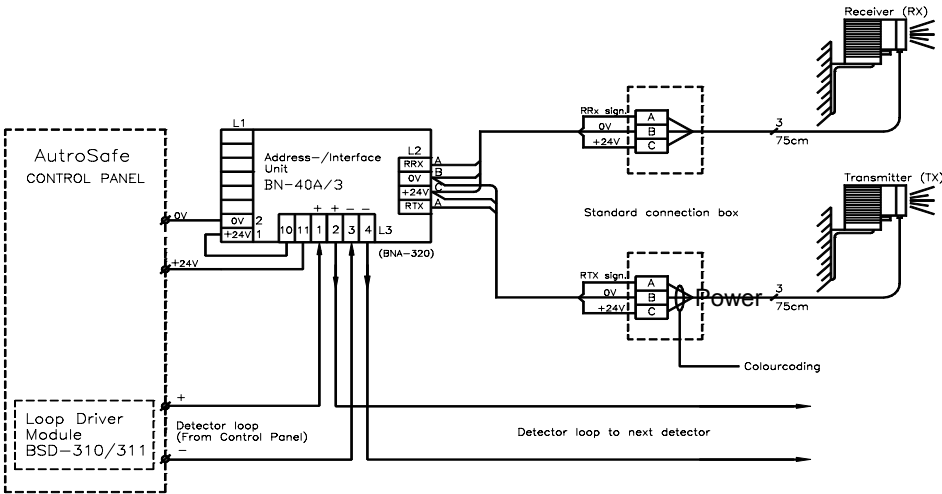

(Drawing No. bs-1160)

6.7 Line Detection with AutoBeam 25

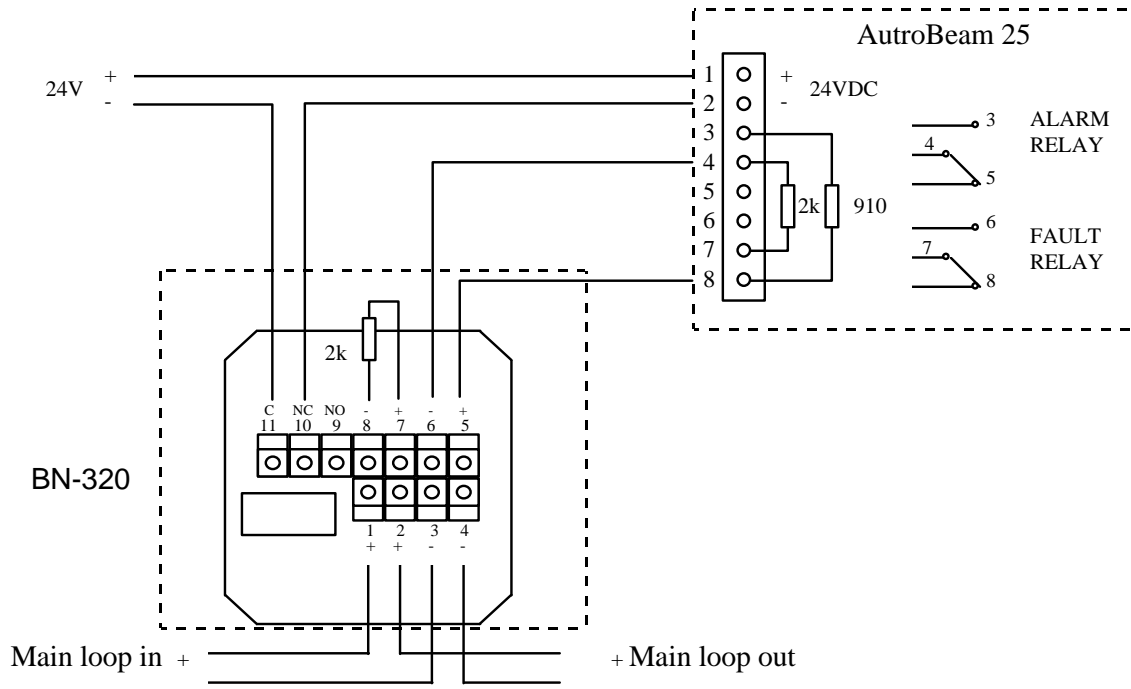
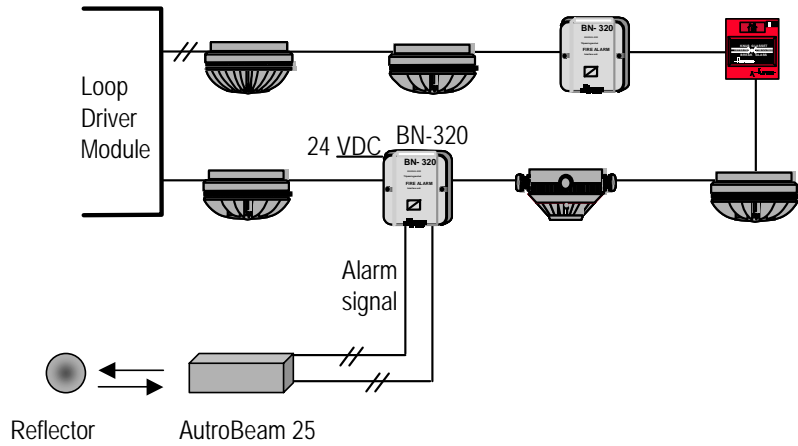

6.8 Programmable Electronic Sounders on the Detection Loop

The Electronic Sounder (BBR-200) has its own address / interface board and can be connected directly to a detector loop. The unit is powered from the detector loop. No external power supply is required.

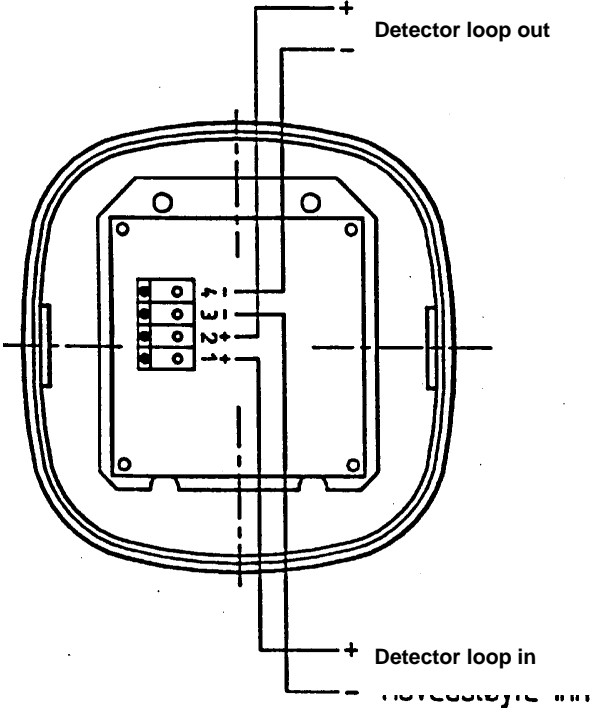
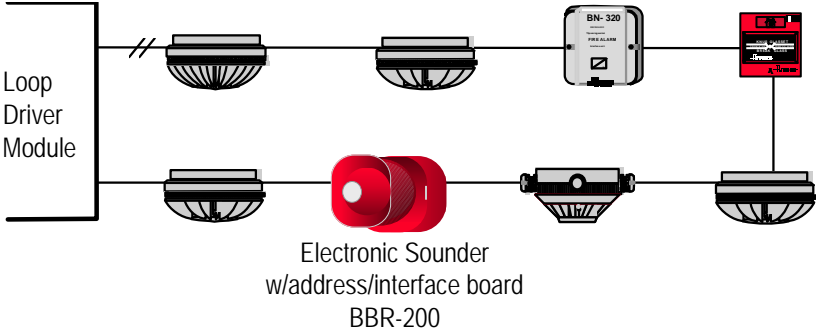

6.9 Addressable Socket Sounder

The Socket Sounder (BBR-110) is a combined detector base and addressable sounder. The unit is powered from the detection loop. No external power supply is required.

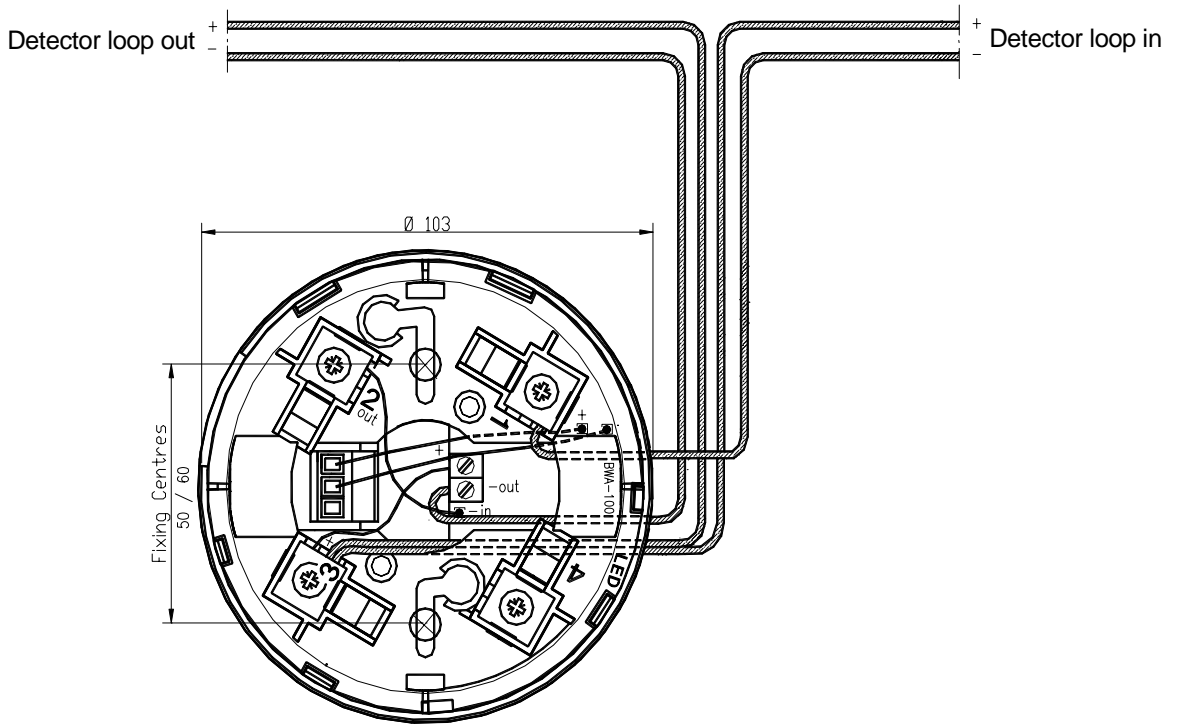
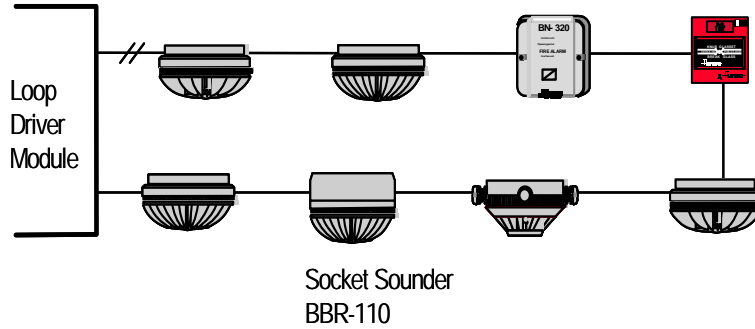

- 1. - in
- 2. - out
- 3. common (+ in, + out)
- 4. external LED

6.10 Ex ia-Approved Detectors

Ex ia-approved detectors can be connected to the system. The *Ex-Barrier Unit (BZ-500)* is used to separate the safe area from the hazardous (Ex) area. A maximum of 20 Ex ia-approved detectors can be mounted as a branch-off from the Ex-Interface Unit on the loop.

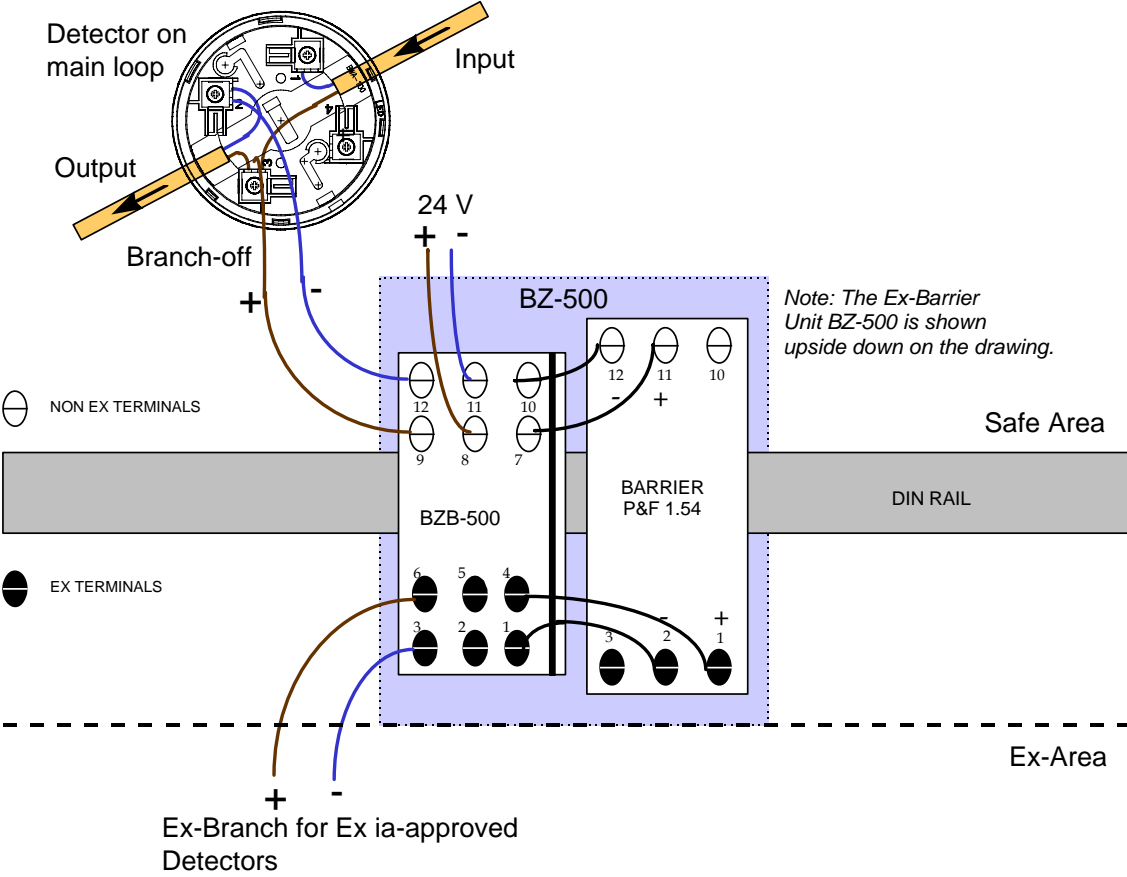
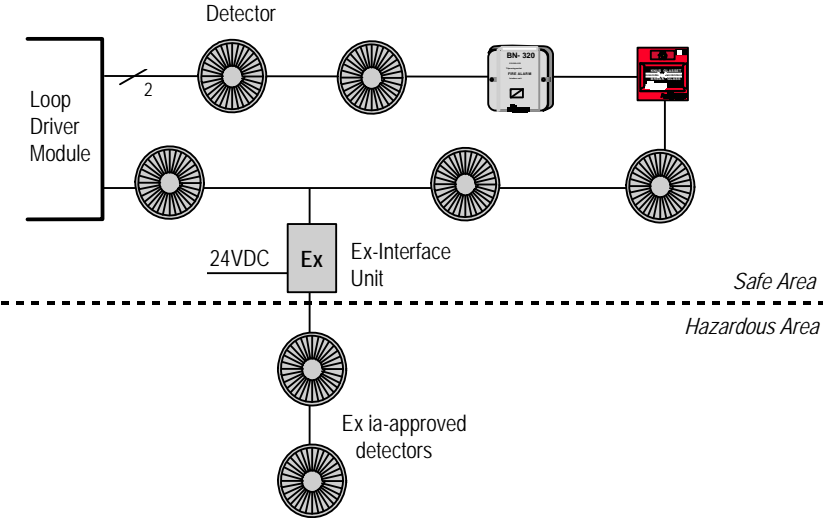

6.11 Disable Input with Pushbuttons

The Disable unit is used to disable one or a number of detection zones. The unit is connected to and powered from the detection loop. The disablement time is configurable (AutoSafe Configuration Tool).

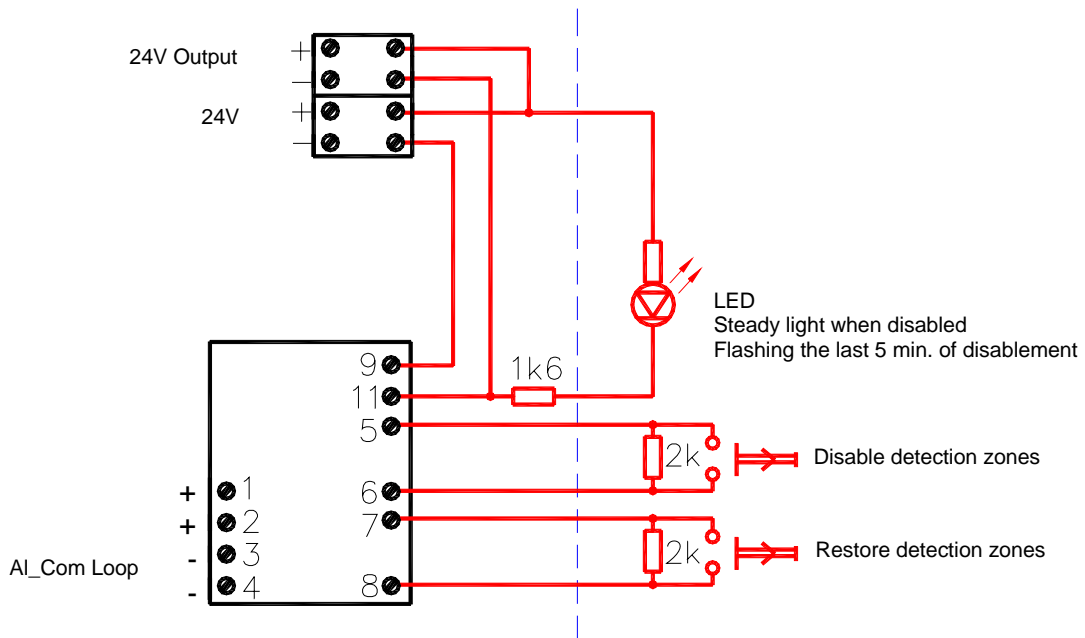
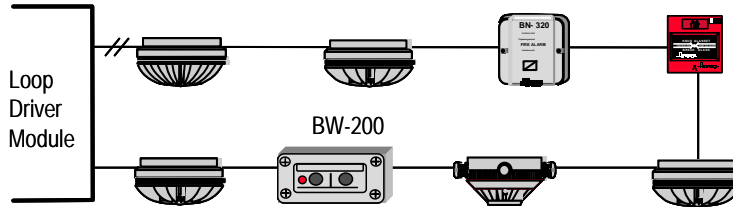

1 or 2 units on each loop: Connect detector loop + 24V to Ø1, and detector loop -24 to Ø3
 More than 2 units on each loop: Use external 24V supply

Separate 24V DC must always be used when control outputs are connected to the loop

6.12 Disable Input with Timer Input

The Disable unit is used to disable one or a number of detection zones. The unit is connected to and powered from the detection loop. An external timer controls the disablement time.

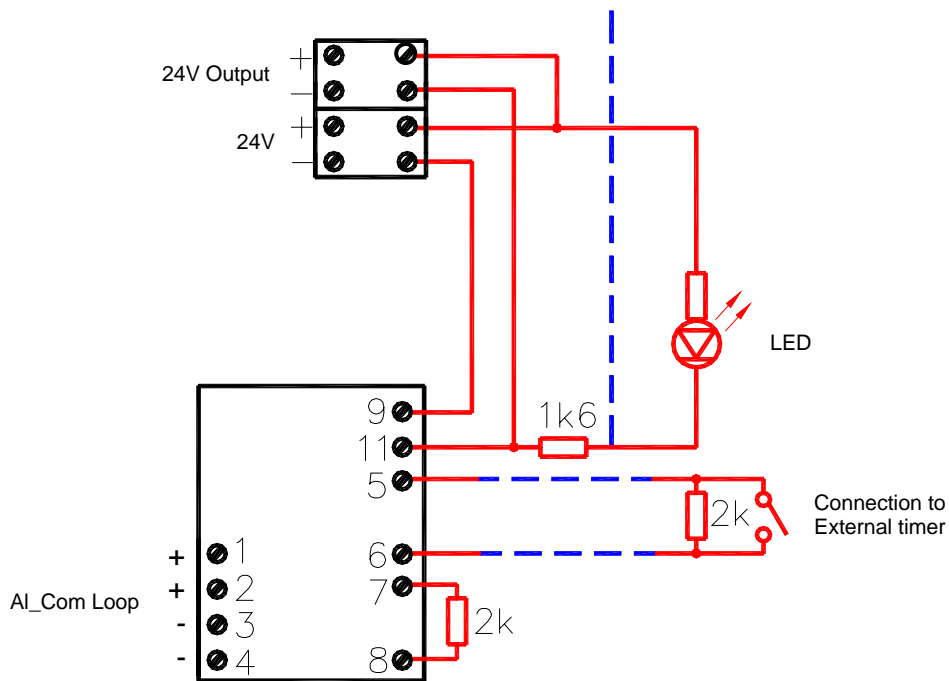
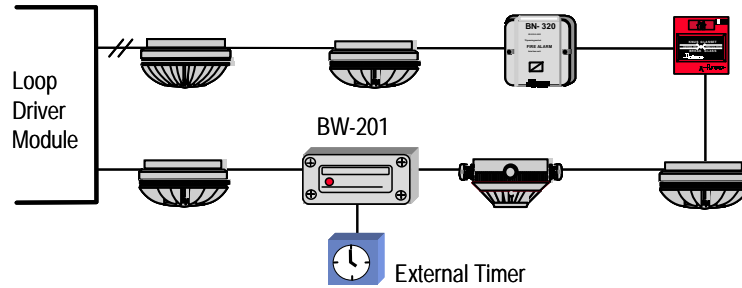

- * 1 or 2 units on each loop: Connect detector loop + to Ø 1, and detector loop - to Ø 3
- More than 2 units on one loop: Use external 24V supply

Separate 24V DC must always be used when control outputs are connected to the loop

6.13 Day/Night Control Unit with Pushbuttons

The Day/Night Control Unit is used for remote operation of the Disable/Enable 'Immediate Output Action' commands. The unit is connected to and powered from the detection loop.

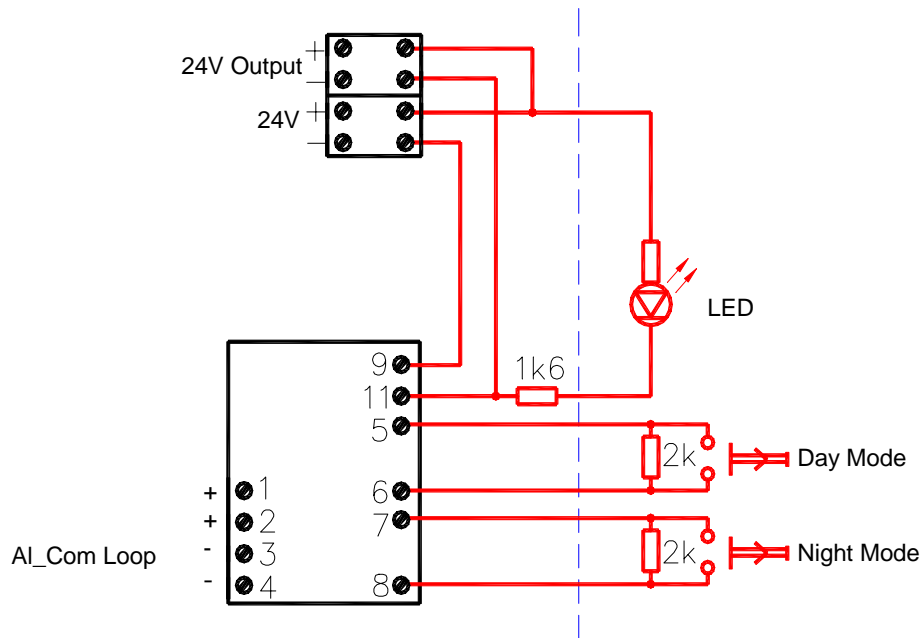
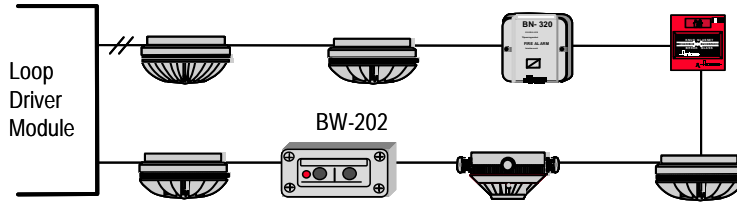

- * 1 or 2 units on each loop: Connect detector loop + to Ø 1, and detector loop - to Ø 3
- More than 2 units on one loop: Use external 24V supply

Separate 24V DC must always be used when control outputs are connected to the loop

6.14 Day/Night Control Unit with Timer Input

The Day/Night Control Unit is used for remote operation of the Disable/Enable 'Immediate Output Action' commands. The unit is connected to and powered from the detection loop. An external timer controls the monitored input.

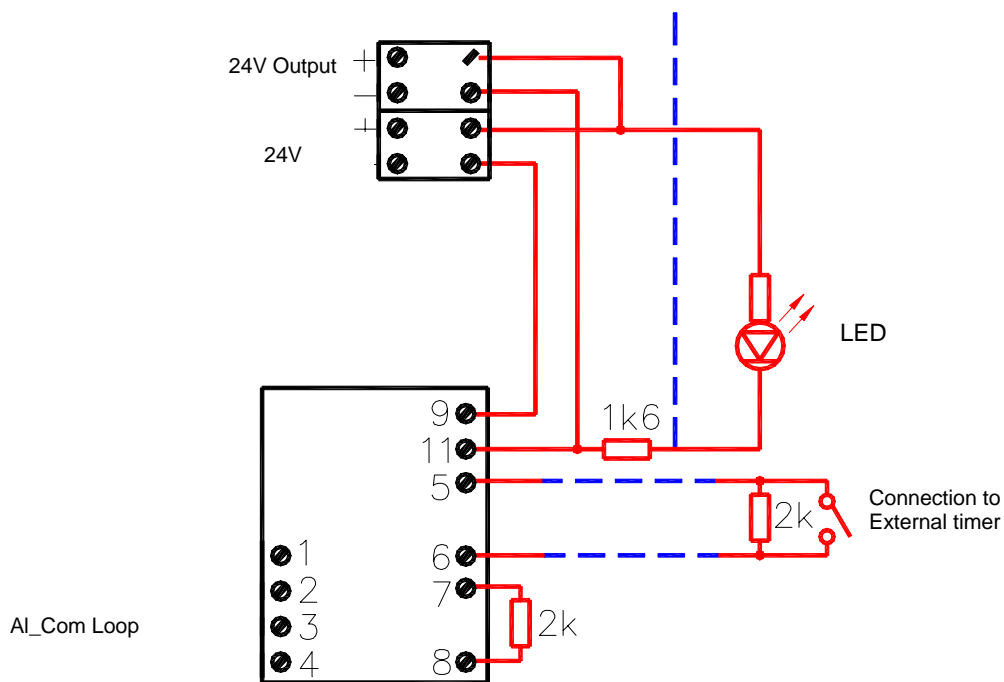
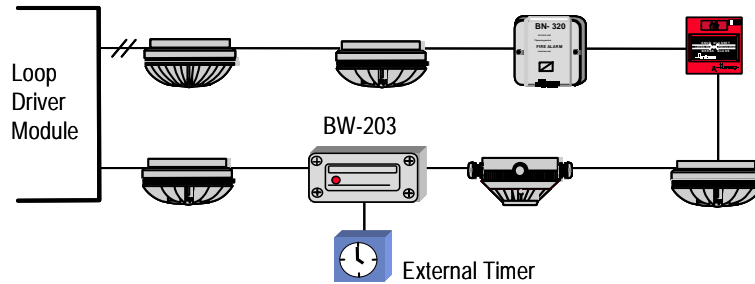

* 1 or 2 units on each loop: Connect detector loop + to Ø 1, and detector loop - to Ø 3
 More than 2 units on one loop: Use external 24V supply

Separate 24V DC must always be used when control outputs are connected to the loop

6.15 Connection of Door Control Unit

The Door Control unit controls and monitors fire doors. The unit is connected to the detection loop, and powered from an external 24V DC power supply.

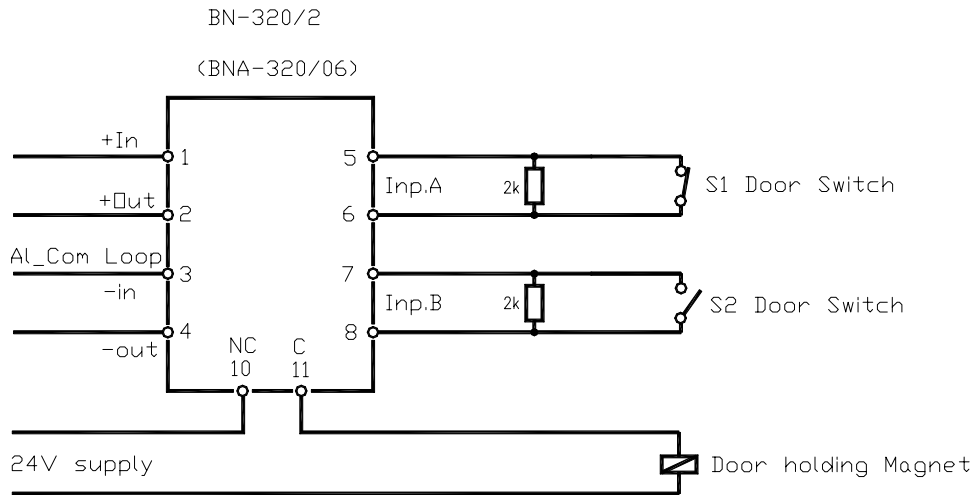
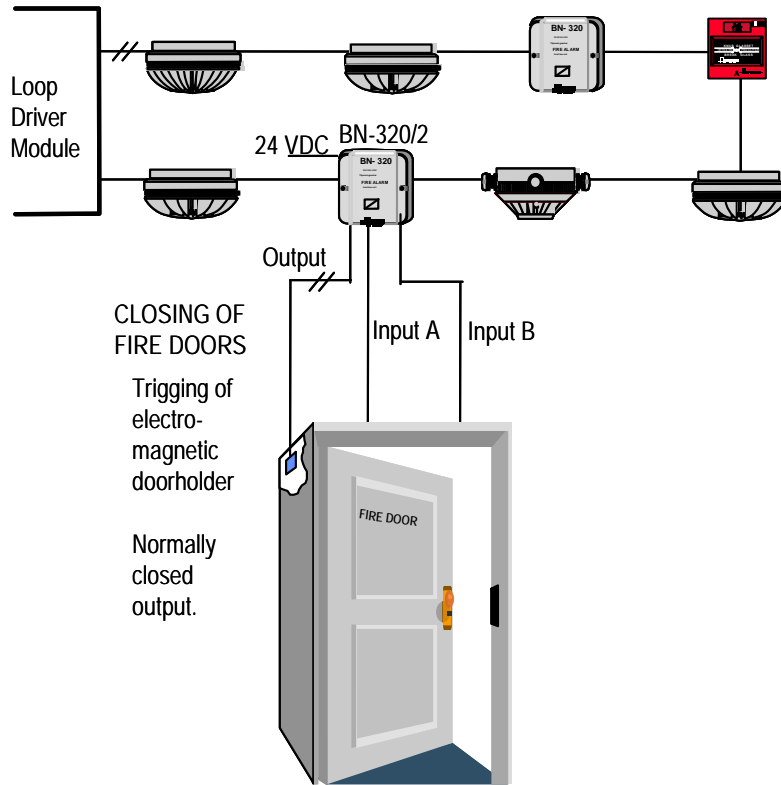

Switch 1	Closed	Open	Open	Closed
Switch 2	Open	Open	Closed	Closed
Status	Door Open	Door in transition	Door Closed	Illegal (fault)

6.16 Connection of Standard Control Unit

The Standard Control Unit monitors and/or controls various external equipment such as control of fire dampers, ventilation valves, fans, lifts, plus fire and smoke hatches. The unit is connected to and powered from the detection loop. External equipment must have separate power supply.

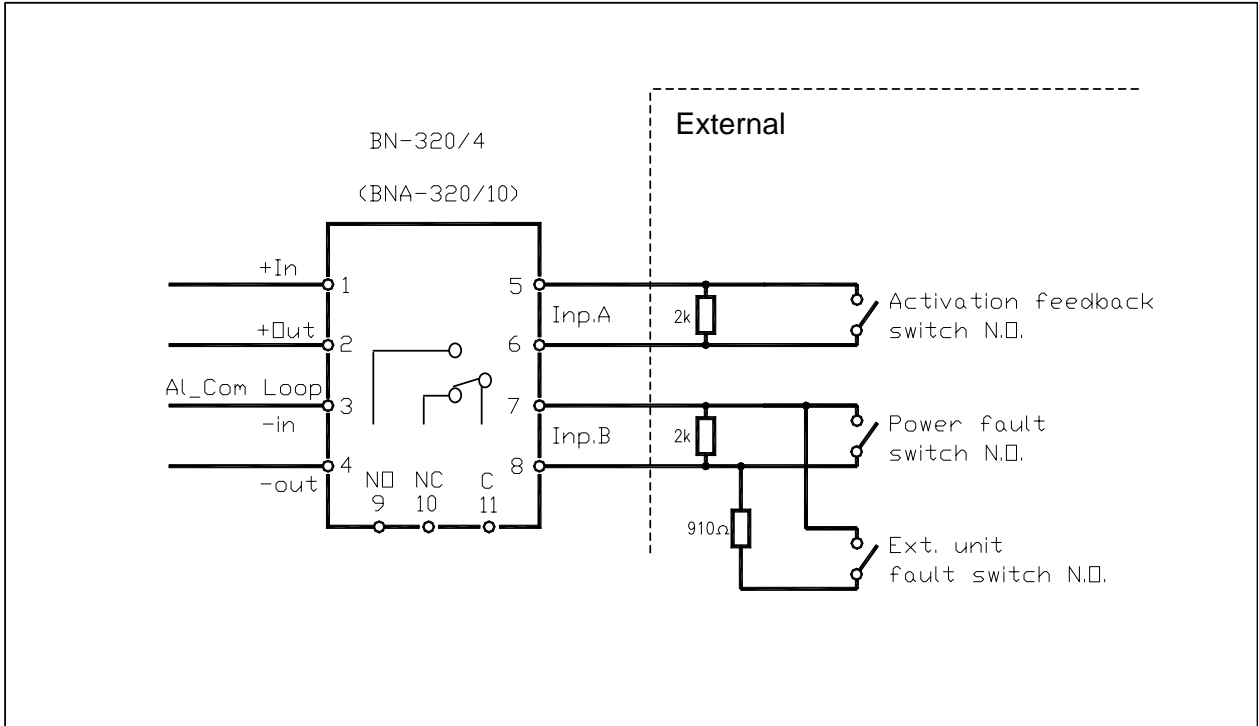
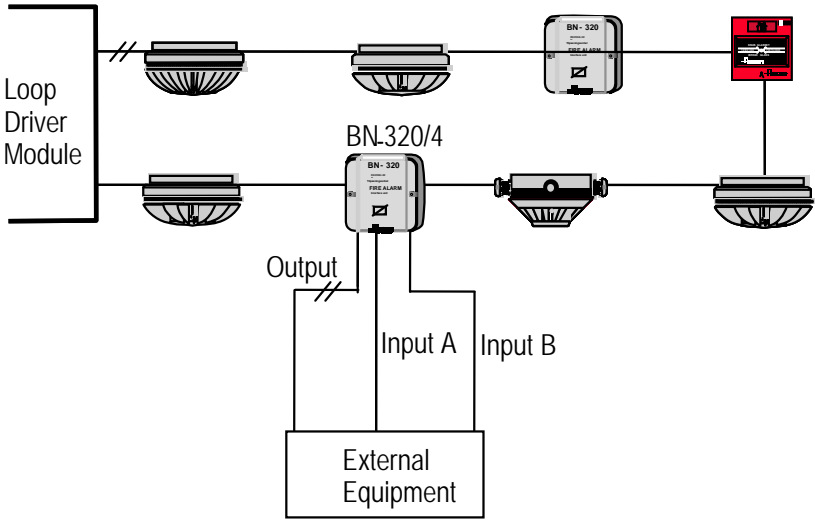

6.17 Connection of Sprinkler Control Unit

The Sprinkler Control Unit is used for monitoring and control of sprinkler systems. The unit is connected to and powered from the detection loop.

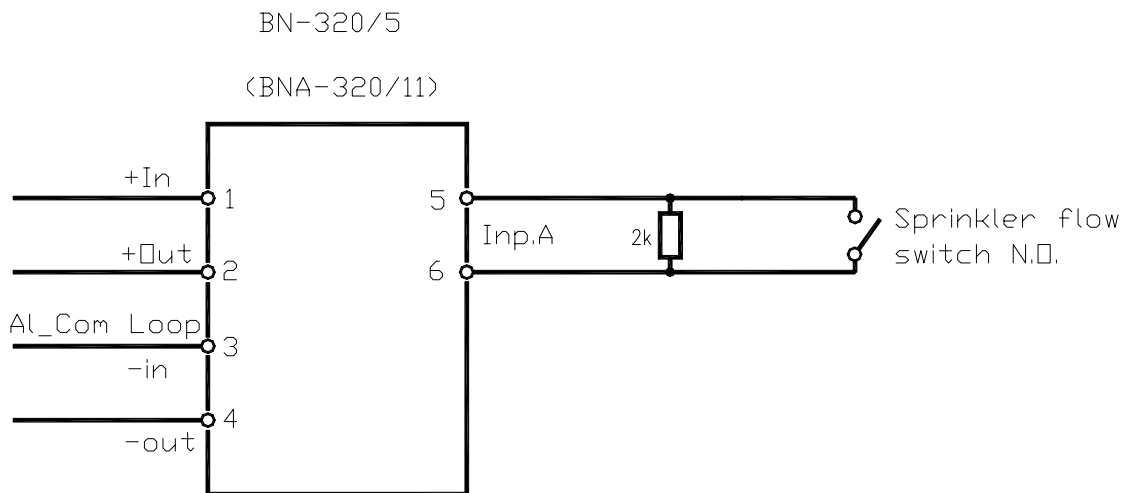
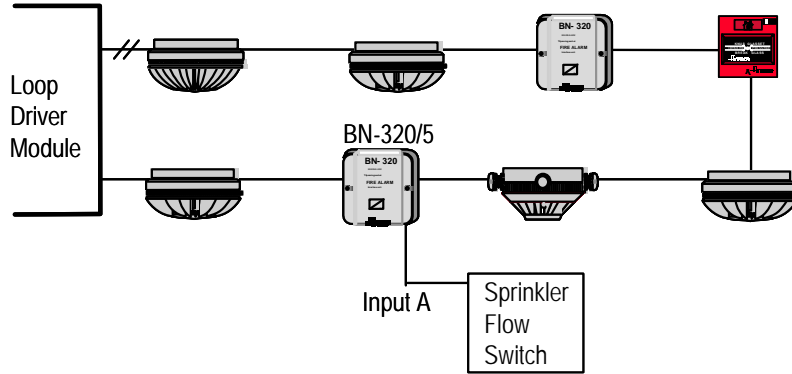

6.18 Connection of Remote Alarm Control Unit

The Remote Alarm Control Unit is used for remote / local alarm handling from predefined areas / zones. The main purpose of the unit is to facilitate alarm handling without disturbance of people and unnecessary calls to rescue services, for example, the fire brigade.

The unit can send acknowledgement and reset to the Control Panel (BS-310/320/330). The Remote Alarm Unit is connected to the detection loop. Each loop unit can be connected to one Operation Zone. An Operation Zone can have one or more units, but requires separate 24V DC power.

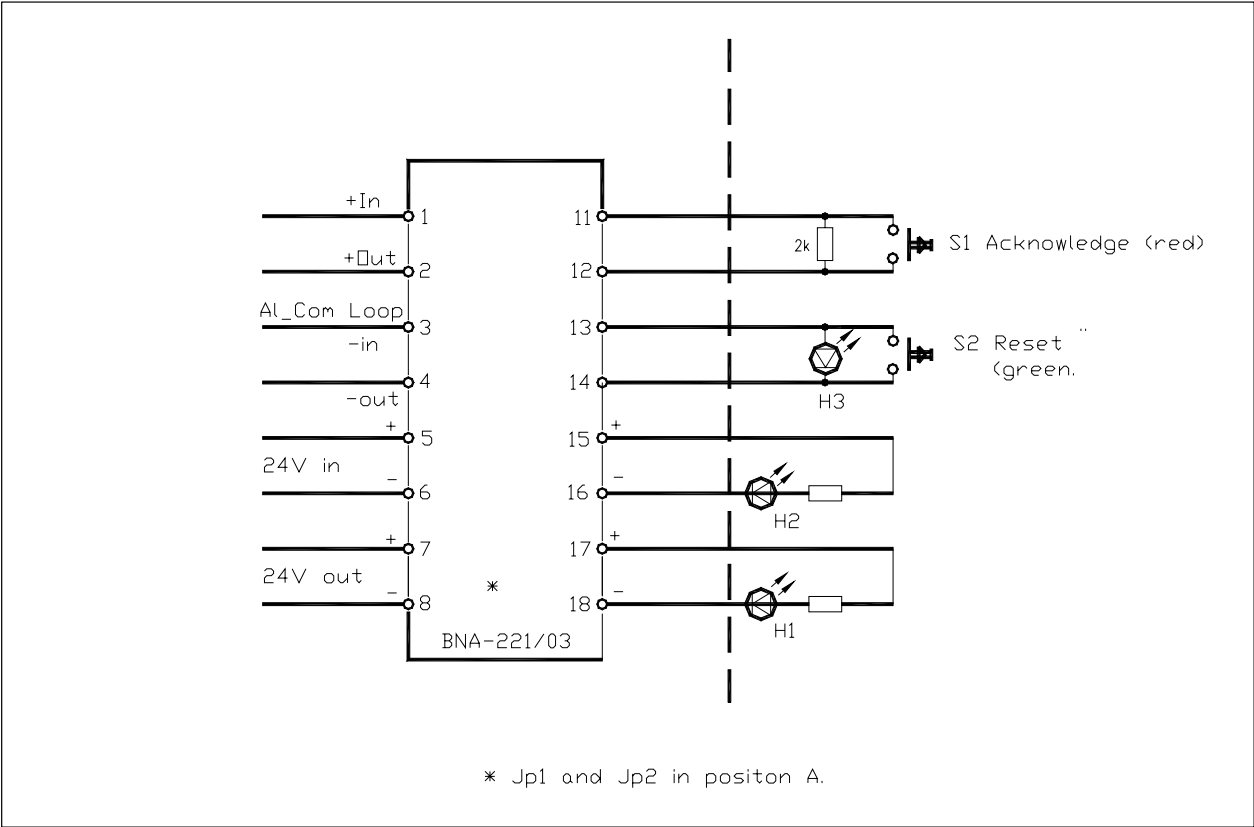
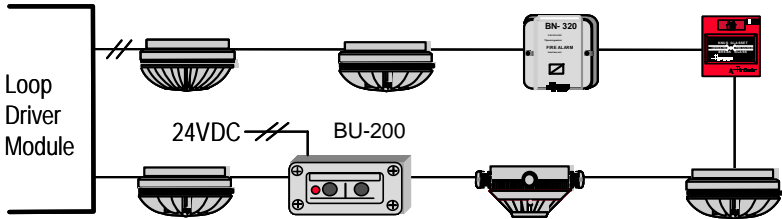

6.19 Connection of Interface Unit for Conventional Loops

The *Interface Unit for Conventional Loops BN-330* consists of a BNB-330 module* mounted on a DIN-rail inside a PCM-box. The conventional detectors are connected to a two-wire sub loop. The sub loop is monitored for broken line by an end-of line unit BNY-330. The interface unit must have a separate 24V supply.

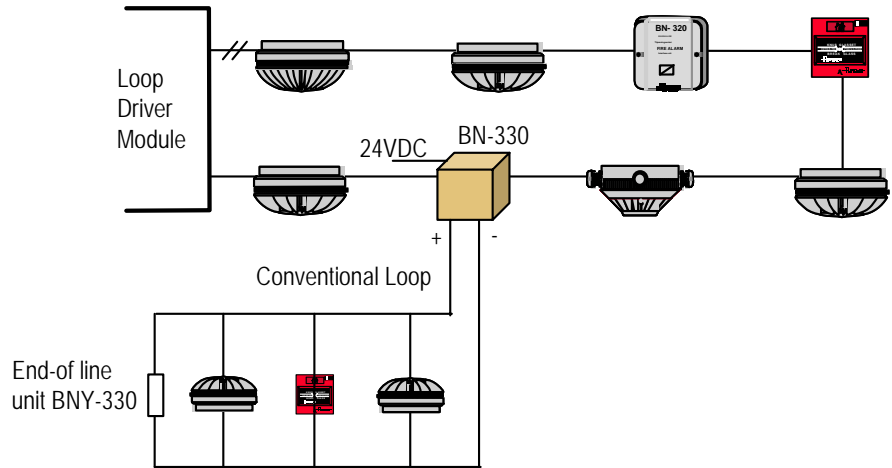

* Variant:

The internal *Conventional Loop Interface Module BNB-330* is mounted on a DIN-rail onto other internal modules inside the Fire Alarm Control Panel / Controller where it is powered with 24VDC.

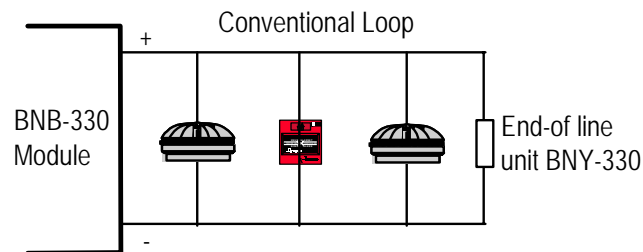

Screw Terminal no.	Signal
1	+ AL-Com in
2	- AL_ Com in
3	+ AL-Com out
4	- AL_ Com out
5	+ 24V Input
6	0V
7	Conventional loop 15V/24V select
8	T-output / Open collector
9	+ conventional loop
10	- conventional loop

7. Larger Distributed Systems

7.1 AUTROLON Rings with Cable Lengths >1km

The maximum length of the AUTROLON ring *without* AUTROLON Boosters is 1km.

AUTROLON Boosters (BSL-325) are required if the AUTROLON cable is more than 1km in length.

The maximum length of a total AUTROLON ring with Boosters is 2,8 km.

7.2 Limitations when using AUTROLON Boosters

The maximum length of a total AUTROLON ring with Boosters is 2,8 km. Boosters must be evenly spread round the AUTROLON ring.

- Maximum 1000 metres between any two Boosters.
- Maximum 8 panels between any two Boosters.
- Maximum 6 Boosters per AUTROLON ring.
- Maximum 32 panels per AUTROLON ring.
- Maximum length 2,8 km (the total AUTROLON ring with Boosters).

7.3 Overview - Cable Connections

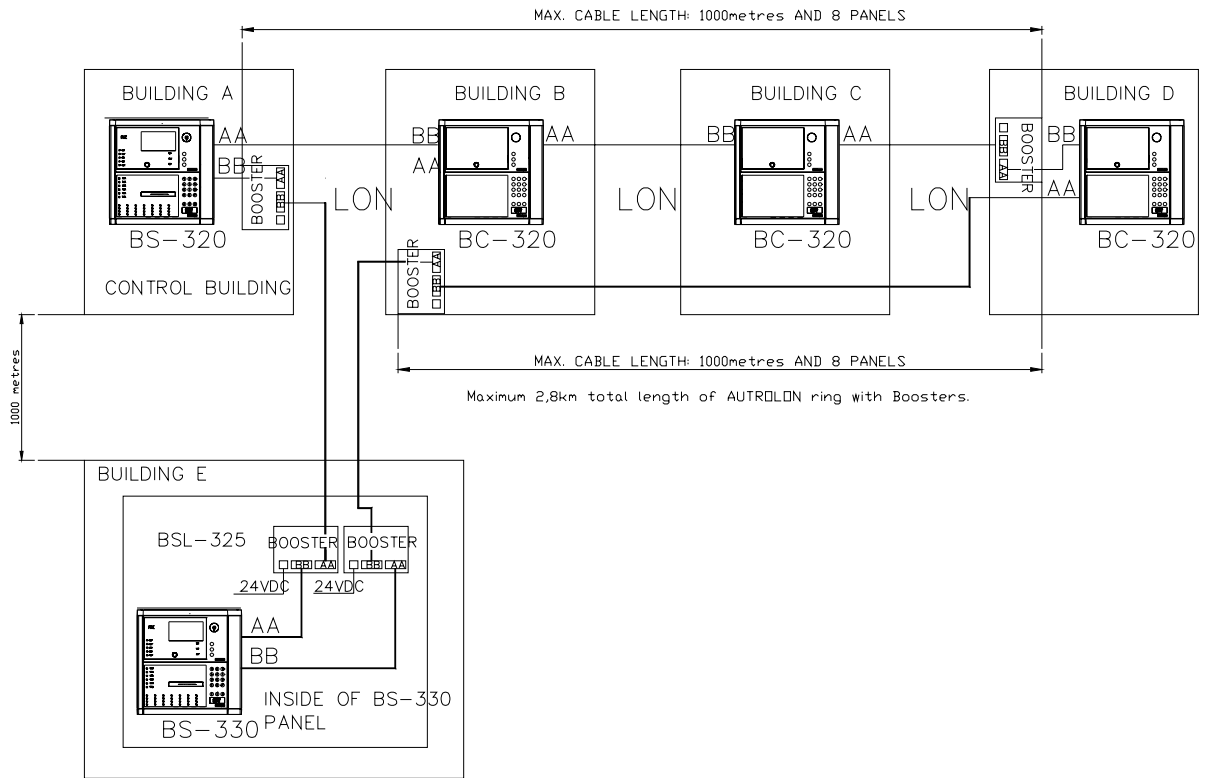

7.4 Connections to the AUTROLON Booster BSL-325

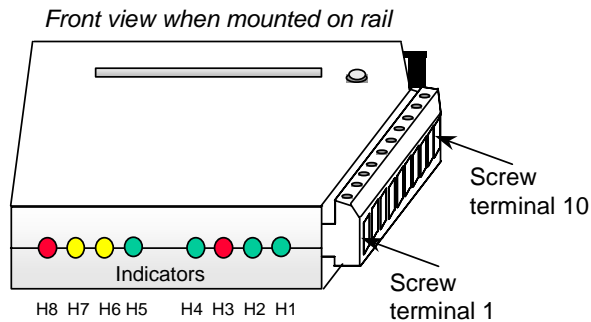

The BSL-325 module has the following connections:

Screw Terminal no.	Signal
1	LON A (polarity independent)
2	LON A (polarity independent)
3	Shield LON A
4	LON B (polarity independent)
5	LON B (polarity independent)
6	Shield LON B
7	Do NOT connect
8	Do NOT connect
9	+24 VDC Supply
10	0 VDC Supply

8. Interfacing AutoMaster 5000

8.1 General

The example below shows part of a larger AutoSafe system connected to an AutoMaster 5000 Colour Graphic System on the top level. The Local Operating Network (AUTROLON) is installed as a ring loop.

A high-level bus based ethernet, *LAN*, can be used between the different work stations in the AutoMaster 5000 system. The AUTROLON is connected to the workstations. The operator panels can be installed in different buildings, operation zones, etc.

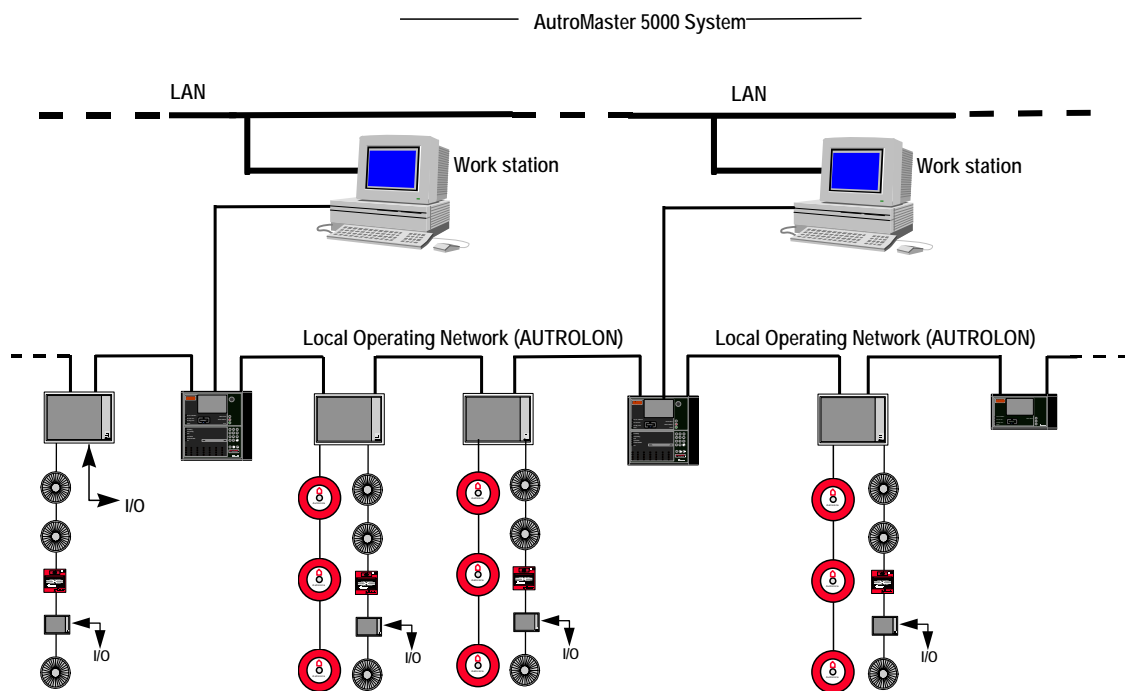

8.2 Connections - Overview

The interface of the AutoMaster 5000 requires the use of the Ethernet Communication Board, EAU-330. The Ethernet Communication Board, EAU-330 is mounted onto the Processor Board EAC-300 inside the Fire Alarm Control Panel BS-310, or on the top of the LON Interface Board (EAU-310/B) inside the Fire Alarm Control Panel BS-320 or Controller BC-320.

The connection can be done via a HUB, or directly to an AutoMaster.

- Connection to a HUB requires a patchcable with internal one-to-one pin connection (straight-through).

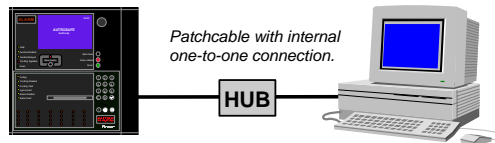

- Connection directly to an AutoMaster requires a patchcable with internal crossing of the TX and RX signals (crossover cable). A convenient way to accomplish this is to do the crossing in a junction box.

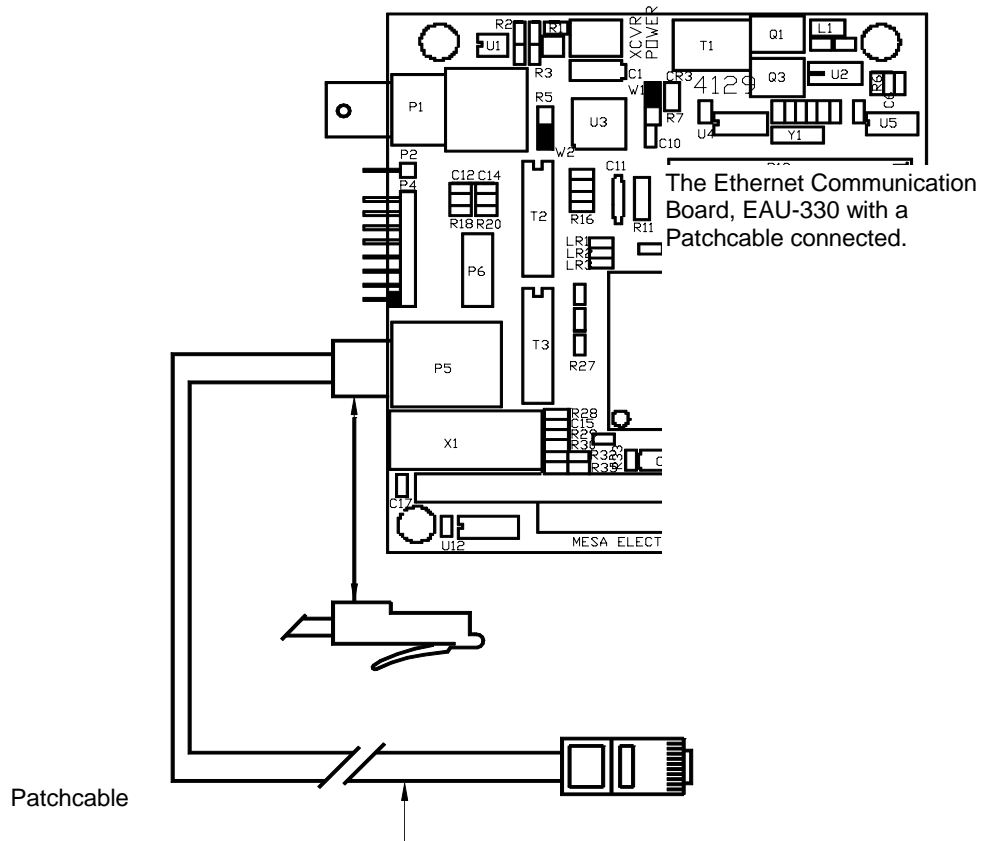
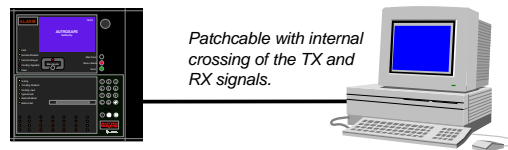

8.3 Application with several AUTROLON rings

8.3.1 General

AutoMaster 5000 is used as the top level system. AutoMaster 5000 enables a two-way communication with both AUTROLON rings and monitors the entire system.

NOTE:

The communication is not possible through AUTROLON rings by use of AutoMaster 5000. The connection from the panels on each AUTROLON ring is done via TP or optical fibre and a HUB to AutoMaster 5000.

The units BN-300 (Fire Alarm Interface Unit) and BN-310 (Relay Output Unit) are used to identify a limited number of alarms between the AUTROLON rings. For this purpose a detection loop on AUTROLON ring 1 is connected to a detection loop on AUTROLON ring 2.

Output (FPE; Fire Protection Equipment) on the BN-310 unit on AUTROLON ring 2 is connected to input (FAI; Fire Alarm Interface) on AUTROLON ring 1 (or opposite). By means of the AutoSafe Configuration Tool, FPE on AUTROLON ring 2 is connected to detection zones (DZ's), which enables alarm transfer to FAI on AUTROLON ring 1. FAI on AUTROLON ring 1 is connected to a detection zone with an appropriate text (for example, Fire, block A2, third floor).

The transfer of control functions is done similarly. By means of the configuration tool, the DZ for FAI on AUTROLON ring 1 must be connected to FPE or alarm output for AUTROLON ring 1.

Note that if the system is configured to, for example, control one output, the current software version does not allow this unless an alarm is shown on panels on AUTROLON ring 1.

The configuration of outputs allows large flexibility. The activation of alarm sounders and control outputs are configurable and the system can be configured to give display texts that will be shown when inputs are activated.

8.3.2 Application with Twisted Pair Cabling

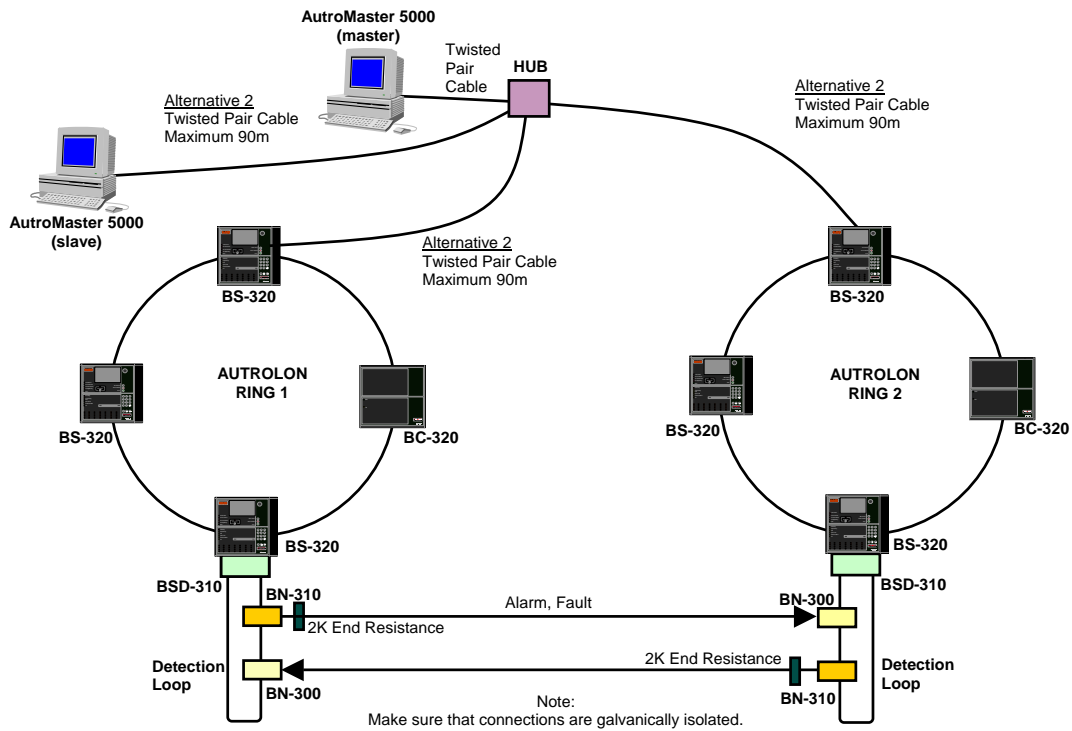

8.3.3 Application with Fibre Optic Cabling

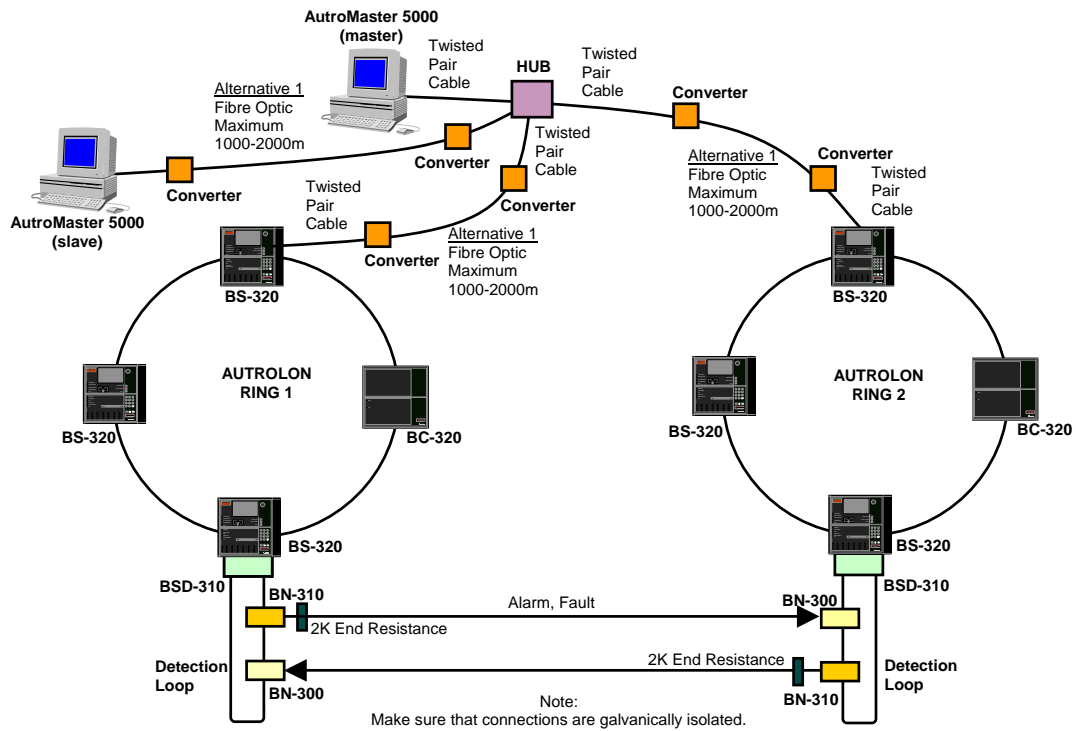

Detail connection drawing

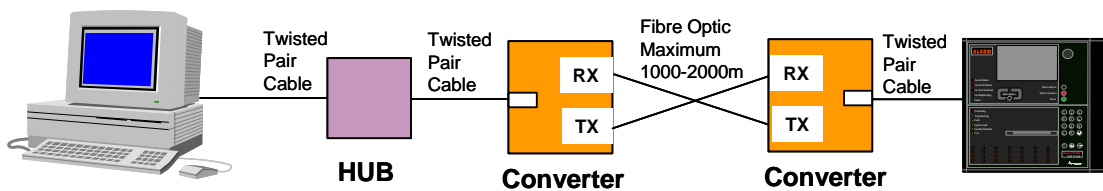

9. Guidelines for the Installation and Addressing of Loop Units

9.1 Introduction

The *guidelines* in this chapter describe the practical tasks which are required during installation and configuration. Note that the order of the different tasks may vary from installation to installation, as well as the technical personnel who are responsible performing the tasks.

The tables for the guidelines (see next pages) are divided into two columns; one for *Installation* and one for *Configuration*. To configure the AutoSafe System, a computer with the *AutoSafe Configuration Tool* is required.

All information regarding configuration is described in detail in the «AutoSafe Configuration Tool Handbook».

9.2 Parameters Used During Configuration

Tag Name (TN), *Production Number (PN)* and *Loop Sequence Index (LSI)* are parameters used during configuration. To be able to fully understand the *addressing* and *configuration* of the system during installation and commissioning, you should get familiarized with these terms.

Parameter	Description	Illustration (example)
<i>Tag Name (TN)</i>	<p>A short <i>system unique</i> description assigned to the Loop Unit location.</p> <p>The Tag Name is a unique, but freely selected name/number (maximum 8 characters) assigned to, for example, a detector socket.</p>	
<i>Production Number (PN)</i>	<p>A <i>Loop Unit unique</i> number (the kind of unit / when and where it was produced).</p> <p>The number is electronically stored in each Loop Unit and presented in readable numbers on a removable sticker.</p>	<p>(Example)</p> <p>00 - 06 - 00 1A AB 87</p> <p>Manufacturer Code + LoopUnit Type + Serial Number</p>

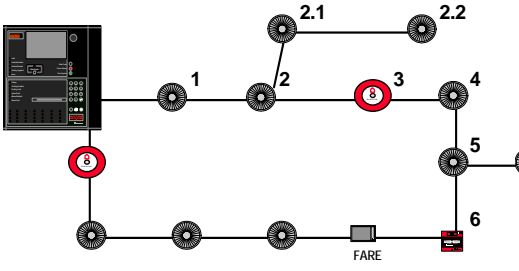
<p><i>Loop Sequence Index (LSI)</i></p>	<p>A loop specific index telling the exact Loop Unit order on the loop (sequentially numbered).</p>	
---	---	--

9.3 Which Parameters are Known?

The guidelines to be followed will depend on whether the *cable layout is known or unknown*. The current situation will determine which parameters are known or not.

Regardless of whether the cable layout is known or not, the *Tag Names* that are to be used for each Loop Unit location should always be marked on the drawings and entered into the Configuration Tool.

- If you have a *known* cable layout, the *Tag Names* and *Loop Sequence Indexes* will be available. Based on this information, the system will be able to automatically find the *Production Numbers*, and connect each Production Number to the corresponding Tag Name.
- If you have an *unknown* cable layout, the *Tag Names* and corresponding *Production Numbers* will be available. Based on this information, the system will be able to automatically find the *Loop Sequence Indexes*.

9.4 Guidelines - *Known* Cable Layout

Step	Installation	Configuration	Known Parameters
1	Make a detailed drawing of the building premises, showing the cable layout with the location of all the different loop units.		
2	Mark all Tag Names on the drawing (at each loop unit location).		
3		Enter the cable layout (loop topology), all loop units and all Tag Names into the AutoSafe Configuration Tool.	At this point the system knows both the Tag Names and Loop Sequence Indexes.
4		Print out the list of all Tag Names.	
5	Do the installation according to the drawings.		
6	Mount each loop unit at its respective location. <i>For verification only:</i> remove and paste the sticker with the Production Number in its correct position on the list, beside the corresponding Tag Name.		When all loop units are mounted, the system will know all three parameters.

9.5 Guidelines - *Unknown* Cable Layout

Step	Installation	Configuration	Known Parameters
1	Obtain a detailed drawing of the building premises. (The cable layout is not shown, as it is unknown).		
2	Mark all Tag Names on the drawing (at each loop unit location).		
3		Enter all Tag Names into the AutoSafe Configuration Tool.	At this point the system knows the Tag Names.
4		Print out the list of all Tag Names.	
5	Install the sockets at all loop unit locations according to the drawings. Mount each loop unit at its respective location. Remove and paste the sticker with the Production Number in its correct position on the list, beside the corresponding Tag Name.		
6		Enter each Production Number into the AutoSafe Configuration Tool beside its corresponding Tag Name.	When all Production Numbers are entered into the Configuration Tool, the system will know all three parameters.

10. Service and Maintenance

10.1 Introduction

The AutoSafe Interactive Fire Alarm System provides a Log Menu, which records all system events, i.e. fire alarms, prealarms, faults, restorations/disablements, user operations and tests.







The owner of the system / authorized personnel has a duty to register all events in a Control Journal.

10.2 Monthly Maintenance

Step	Description	4
1	Look through the log journal to find any possible irregularities.	
2	Make sure that possible changes in the building structure or storage environment have not affected the detectors' capability to detect a potential fire.	
3	Make sure that the detectors are not covered with paint or contaminated with dust or dirt.	
4	Perform a visual inspection of the Fire Alarm Control Panel.	
5	Perform a simple test of display and panel functions	
6	Test the sounders.	

10.3 Annual Service and Maintenance

The whole system (control panel, detectors, control functions) should be inspected annually. An annual service inspection comprises the following:

Step	Description	4
1	Test the panel indicator lights and internal buzzer by pushing the Mute button more than 5 seconds.	
2	<p>Test all operating keys by pressing each key:</p> <p>The following buttons will give a short "Beep" when pressed:</p> <p>All the <i>alphanumeric</i> buttons, plus;</p> <p>the red <i>Silence Alarms</i> , <i>Cancel</i> , <i>Enter</i> , <i>Help</i> , <i>Close</i> </p> <p>The green <i>Reset</i> button  should reset the system (requires access level 3).</p> <p>The <i>Menu</i> button  should allow you to switch between Menu Mode and Operation Mode.</p>	
3	Perform a visual and functional inspection of manual call-points and automatic detectors.	
4	Activate the alarm system. Test all sounders by activating an alarm from a corresponding manual call-point.	
5	Test all control functions.	
6	Disable any alarm transference to the Fire Alarm Routing Equipment -FARE output.	
7	Activate alarms from at least one detector/manual call-point in each zone and a check that all respective outputs are activated.	
8	Test the action of any auxiliary operating functions (disabling, cancelling and resetting buttons).	
9	Check the alarm transference outputs by connecting from outgoing outputs (potential free relay and 24V output) activated by alarm in a zone.	
10	<p>Check the fault warning function from detector zones by removing a detector in each zone.</p> <p>Activate a fault (remove battery fuse) and observe:</p> <ul style="list-style-type: none"> - the <i>Fault</i> indicator starts to blink - a fault warning is displayed - the internal buzzer is turned on - the Fault Warning Routing Equipment (FWRE) output is activated (if any) 	
11	<p>Verify all <i>conditions</i>, i.e.:</p> <ul style="list-style-type: none"> - Fire Alarm condition - Fire Warning condition - Fault Warning condition - Disablement condition - Test condition 	
12	Check the battery voltage by disconnecting the charger and measure the voltage across the battery after approx. 1-2 minutes (depending on the load). The voltage should be >24.5V.	
13	On completion of checks, ensure that only the green "Power" indicator is on when the panel is in its idle state (normal operation).	
14	Complete a service report and service log.	

The battery should be changed every 4 years. If a fault arises on the panel that cannot be rectified, contact your nearest Autronica Fire and Security office for qualified assistance.

11. Reader's Comments

Please help us to improve the quality of our documentation by returning your comments on this manual:

Title: Installation Handbook, Fire Alarm Control Panel BS-310/320 / Controller BC-320 -,
AutoSafe Interactive Fire Alarm System, Release 3,
Ref. No.: 116-P-ASAFE-FA/DE, Rev. G, 2007-06-19

Your information on any inaccuracies or omissions (with page reference):

Please turn the page

Suggestions for improvements

Thank you! We will investigate your comments promptly.

Would you like a written reply? Yes No

Name: -----
Title: -----
Company: -----
Address: -----

Telephone: -----
Fax: -----
Date: -----

Please send this form to: Autronica Fire and Security AS
 N-7483 Trondheim
 Norway

Tel: + 47 73 58 25 00

Fax: + 47 73 58 25 01

www.autronicafire.com/

Autronica Fire and Security AS is an international company, based in Trondheim, Norway and has a world-wide sales and service network. For more than 40 years Autronica's monitoring systems have been saving lives and preventing catastrophes on land and at sea. Autronica Fire and Security's most important business area is fire detection & security. Autronica Fire and Security stands for preservation of environment, life and property.

Quality Assurance

Stringent control throughout Autronica Fire and Security assures the excellence of our products and services. Our quality system conforms to the Quality System Standard NS-EN ISO 9001, and is valid for the following product and service ranges: marketing, sales, design, development, manufacturing, installation and servicing of:

- fire alarm and security systems
- petrochemical, oil and gas instrumentation systems for monitoring and control

In the interest of product improvement, Autronica Fire and Security reserves the right to alter specifications according to current rules and regulations.

Autronica Fire and Security AS

Fire and Security, Trondheim, Norway. Phone: + 47 73 58 25 00, fax: + 47 73 58 25 01.

Oil & Gas, Stavanger, Norway. Phone: + 47 51 84 09 00, fax: + 47 51 84 09 99.

Autronica Industrial Ltd., Watford, United Kingdom. Phone: 1923 23 37 68, fax: 1923 22 55 77.

Visit Autronica Fire and Security's Web site: <http://www.autronicafire.com/>