

Conventional Fire Detection and Fire Alarm Systems

MF9300

Conventional fire panel

The Menvier MF9300 Series of conventional fire panels truly represents a high specification at a competitive price.

The panels have been developed specifically to meet fully the European fire alarm standard EN54 Parts 2 and 4: 1998, and the requirements of BS 5839 Part 1 installation whilst retaining the Menvier traditions associated with ease of installation and operation.

Innovative design and advanced production techniques enable many features to be incorporated within the standard specification, usually only available at extra cost.

MF9300 Series control panels provide system design flexibility, ease of installation and simple operation and are suitable for use in a wide range of building types and sizes.

Installation

Every effort has been made to ensure ease of installation. All PCB assemblies, control and indication components are removed with the panel front plate, providing an accessible back box for either surface or flush fixing.

The back box provides appropriate knockouts for cable entry at both top and rear. A 7mm flanged step in the box wall enables the standard back box to be flush fixed without the addition of special surface fixing bezels.

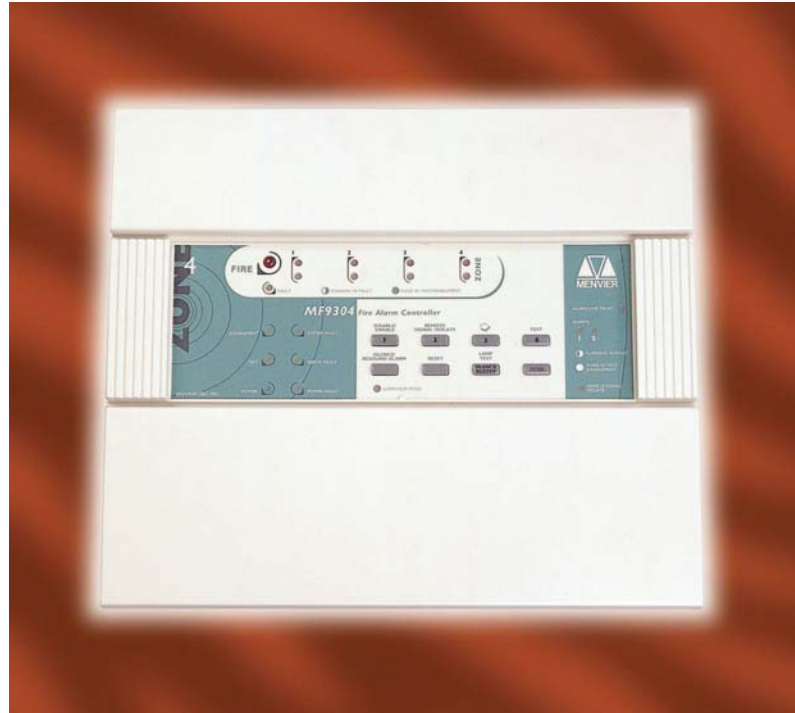

With the panel front plate positioned, ample space has been allowed for ease of cable termination.

System features

The MF9300 Series provides features, as standard, making it a leader in current fire alarm system design.

Every effort has been applied to the design to enable extensive facilities to be provided at a cost usually associated with basic fire alarm panels. The Menvier MF9300 Series offers flexibility, enabling it to meet most system requirements in its standard form.

The panel is available as 2, 4, 8 and 16 zone versions, designed to meet fully the requirements of BS EN54 Parts 2 and 4: 1998. The MF9300 Series is designed to comply fully with the European Directives covering EMC and low voltage electrical equipment and is Year 2000 compliant.



Detector zones

- * All zones are fully monitored for open, short circuit and detector removal conditions
- * zones can be disabled individually, for service and maintenance
- * One man walk test – enables a full system test by one man, by allowing individual call points, detectors and sounders to be automatically reset, each time a device is tested without the engineer having to return to the control panel. A fire condition received on a zone not in test mode, results in an immediate alarm, overriding the test mode.
- * lamp test facility allows all LED indications and the panel buzzers to be tested.
- * Non-latching zone (2 zones and above) is a selectable facility on one zone enabling the direct interconnection of panels.
- * Coincidence facility (4 zones and above) available as a selectable facility on one zone. An alarm condition is dependent upon a fire signal from two detectors within a predetermined time period. Any fire signal from a manual call point on the zone operates an alarm immediately.

Alarm lines

- * 2 separate alarm lines are provided. For ease of installation and system design, 4 alarm lines are provided as standard on all 8 and 16 zone panels.
- * all alarm lines are fully monitored and can be disabled for service and maintenance.
- * alarm delay (4 zones and above) is a selectable feature. This enables delays to be preset from one to seven minute periods. The panel automatically indicates when a delay is in operation. Fire signals from manual call points will result in immediate fire alarm action.

System control facilities

- * Earth fault monitoring – the system will indicate faults due to earth leakage in system wiring
- * External input (2 zones and above) – provides sounder operation for non-fire events, e.g. school class change, emergency building evacuation
- * Auxiliary DC output (2 zones and above) – a 24V DC output supply, switchable by the panel auxiliary relays or used to drive external relays
- * Auxiliary fault relay (4 zones and above) provides volt free output for any fault condition registered by the panel
- * Remote signal relay (2 zones and above) operates on the activation of any fire zone for signalling to a remote location, or for the operation of an auto-dialler. The facility can be isolated for system test and service purposes
- * Auxiliary common output (2 zones and above) provides a facility for driving external relays in order to operate door release units or other devices directly from fire signals.

Note: This output does not operate if a non-latching zone option has been selected.

Repeater panels

Repeater panels, matching in style and appearance the MF9300 Series main control units are available in 8 and 16 zone versions.

Facilities are provided on all panels on 4 zones or more for signalling to repeater panels. The repeater units enable essential information to be displayed at other key locations around a building or on a large site.

All signals are transmitted from the main panel to the repeater unit by a single pair of wires, substantially reducing the cost of installation, especially on larger systems. In order to provide this serial link, a mains supply is required at the repeat panel.

Features

The MF9300 Series repeater panel will display the following fire alarm system conditions:

- * fire and fault conditions on a zonal basis
 - * zones and alarm lines in test mode
 - * zones and/or alarm lines in disabled mode
 - * any delays present on the alarm line circuits
 - * faults, isolations and test mode for control outputs
- In addition, the user can carry out the following operations at the repeat location.
- * silence the internal fire and fault warning buzzer within the repeater panel
 - * operate repeater lamp test

System controls and indications

User controls have been designed for clarity and ease of operation. Simple push button control and clear LED indication have been retained throughout the range.

Access levels

Control access is provided at four separate levels in order to comply fully with BS EN54 Pt 2: 1998. All system user controls are available at level 2, with further access required for service engineering and manufacturers.

Access to all facilities, panel operations and system control is by key code entry using eight large, clearly labelled push buttons.

All LED indications are backed, where required, by clear tone internal panel buzzer.



Fire System MF9300

Electrical Data	
Main panel	
System operating voltage – 24V DC	
Primary power supply – 230V AC \pm 10% at 50 Hz	
Secondary power supply – sealed lead acid batteries providing 72 hours standby on mains failure	
End of line monitoring unit – detection circuits – 12K resistor – alarm circuits – 12K resistor	
Auxiliary DC output	
	2 and 4 zones – 24V DC 100mA unmonitored (fused)
	8 and 16 zones – 24V DC 350 mA max unmonitored (fused)
Auxiliary fault relay (4 zones and above) – 1A 24V DC (resistive) single pole, change over contacts operate on any fault condition	
Remote signal relay (2 zones and above) – 1A 24V DC (resistive) single pole, change over contacts operate on any zone signal general alarm condition	
Auxiliary common output (2 zones and above) – pull down to 0 volts. Operates on general alarm condition in any latching zone.	
Repeater panel	
Signal interface	2 wire serial link
Mains supply	230V AC \pm 10% 50 Hz
Standby duration	72 or 24 hours

Mechanical Data		
Overall Dimensions	395mm wide x 344mm high x 95mm deep max	
2 and 4 zone panel	395mm wide x 386mm high max x 144mm deep max	
8 and 16 zone panel	395mm wide x 386mm high max x 144mm deep max	
Finish 2 and 4 zone panel	front panel	high impact polycarbonate ABS
	back box	high impact polycarbonate ABS
Finish 8 and 16 zone panel	front panel	high impact polycarbonate ABS
	back box	steel

Specification				
	MF9302	MF9304	MF9308	MF9316
No. of zones	2	4	6/8	12/16
Detectors per zone	32	32	32	32
No. of alarm circuits	2	2	4	4
Alarm circuit load	500mA per line (1A total)	500mA per line (1A total)	1A per line (2A total)	1A per line (2A total)
Mains input voltage	230V AC \pm 10% 50/60Hz	230V AC \pm 10% 50/60Hz	230V AC \pm 10% 50/60Hz	230V AC \pm 10% 50/60Hz
System operating voltage	24V DC	24V DC	24V DC	24V DC
Standby duration	72 or 24 hrs	72 or 24 hrs	72 or 24 hrs	72 or 24 hrs
Integral charger	24V 900mA	24V 900mA	24V 1300mA	24V 1300mA
Battery capacity	7AH	7AH	12AH	12AH
Recharge period	24hrs	24hrs	24hrs	24hrs
Weight	10.6kg	10.6kg	16.8kg	16.9kg

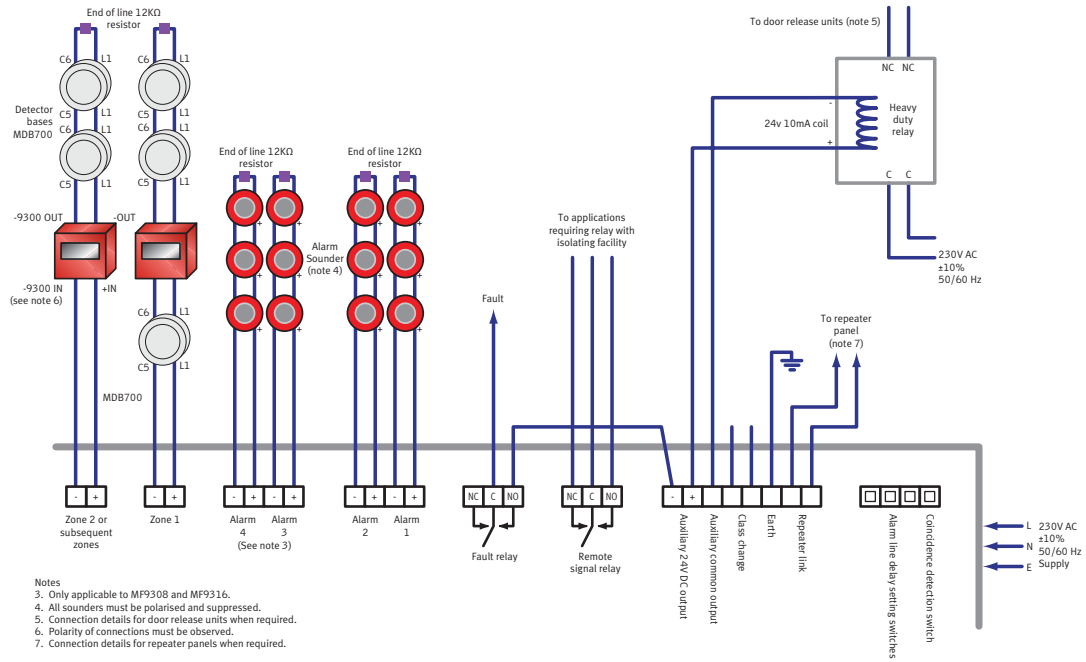

Conventional Equipment – Order Codes	
MF9302	2-Zone Fire Panel c/w Batteries (72 hour standby)
MF9304	4 Zone Fire Panel c/w Batteries (72 hour standby)
MF9308	6/8 Zone Fire Panel c/w Batteries (72 hour standby)
MF9316	12/16 Zone Fire Panel c/w Batteries (72 hour standby)
MF9308-L	6/8 Zone Fire Panel c/w Batteries (24 hour standby)
MF9316-L	12/16 Zone Fire Panel c/w Batteries (24 hour standby)
MFR9308	8 Zone Repeater Panel c/w Batteries
MFR9316	16 Zone Repeater Panel c/w Batteries

